

araven

FOOD SAFETY INNOVATION

2026

[CFS BRANDS]



Innovación al servicio de la seguridad alimentaria

ARAVEN es una compañía internacional dedicada al diseño, fabricación y comercialización de artículos para el profesional de la Hostelería.

Desde 1976 desarrollamos herramientas de trabajo fáciles y cómodas de usar, versátiles y con todas las garantías en materia higiénico-alimentaria, que ayudan a cumplir las normativas y a desarrollar el trabajo diario en la cocina. Ofrecemos asesoramiento y formación, sobre los productos, condiciones de uso y cumplimiento de normativas. Nuestro equipo de profesionales garantiza en todo el mundo un servicio y una atención personalizada.

ARAVEN colabora con prestigiosas escuelas de gastronomía, asociaciones y reconocidos chefs nacionales e internacionales. Nuestro Departamento de Innovación trabaja en estrecho contacto con los profesionales para conocer las necesidades del trabajo diario y desarrollar nuevos productos adaptados a ellas. También contribuimos a la formación de los futuros chefs y al equipamiento de sus cocinas con nuestro plan de apoyo al sector hostelero.

Nuestro objetivo es desarrollar el negocio de nuestros clientes y el sector aportando eficiencia en la cocina y asegurando la máxima calidad de los alimentos en todos sus procesos.



INSTITUT
Lyfe



basque
culinary
center

gasma
GASTRONOMY & MANAGEMENT
UNIVERSITY CAMPUS

Fundación
Cruzcampo

wk
Westminster Kingsway
central London's College



Pedro Subijana



Martín Berasategui



Enrique Olvera



Jesús Almagro

AKELARE
PEDRO SUBIJANA

Martín Berasategui

ENRIQUE OLVERA

 JESÚS
ALMAGRO
COCINA & PASIÓN



Pascal Barbot



Naumi Uemura



Antonio Arrabal

Astrance
PARIS



UEMURA

 LAJA
MADA

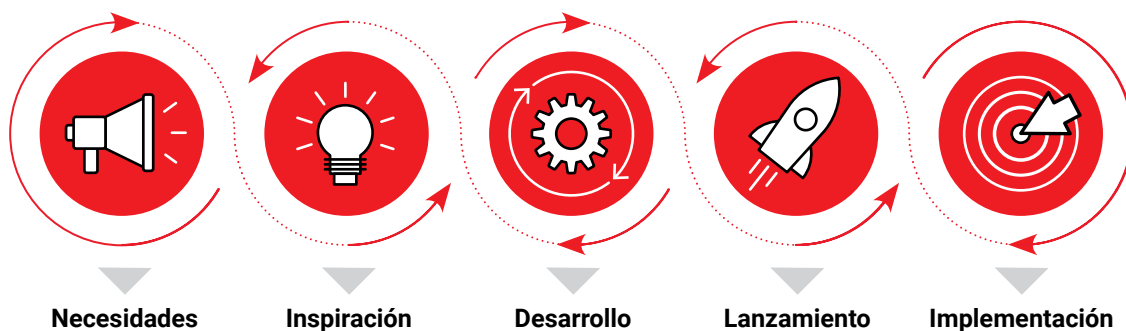

Innovación

ARAVEN apuesta por la innovación, es el eje principal de creación de valor. Trabajamos constantemente para superarnos y hacer crecer el sector desarrollando productos que generan un valor superior para nuestros clientes y usuarios. Incorporamos los últimos avances en materiales, procesos productivos y sistemas de producción a nuestros productos.



Productos desarrollados por y para los cocineros. **Nuestro objetivo es generar nuevos conceptos de máxima funcionalidad para el profesional de la hostelería.** Contamos con la colaboración de expertos consultores en seguridad alimentaria, así como cocineros de todo el mundo, que aportan su experiencia y conocimiento para que el diseño del producto responda a las necesidades del trabajo más exigente. Los comentarios recibidos de los profesionales de las cocinas y la observación in situ de sus procesos, junto a la investigación en seguridad alimentaria, son la base para el desarrollo de nuevos productos.

ARAVEN busca cómo ofrecer algo único al profesional, poniendo al usuario en el centro de nuestros desarrollos con soluciones que garantizan la conservación y manipulación del alimento y el cumplimiento de la normativa en materia higiénico-alimentaria y contribuyen a la excelencia operativa.

1. ¿Cómo optimizar el espacio?
2. ¿Cómo agilizar el trabajo en la cocina?
3. ¿Cómo cumplir con las normativas sanitarias?
4. ¿Cómo ofrecer algo único que ayude al profesional?

Si eres profesional de la hostelería queremos simplificar tu día a día en la cocina con herramientas fáciles y cómodas de usar, versátiles y con todas las garantías en materia higiénico-alimentaria. Ofrecemos productos que ayudan a cumplir las normativas y a desarrollar el trabajo diario con seguridad y confianza.

Contamos con patentes y registros en más de 25 países que protegen nuestros desarrollos más innovadores.



¿Qué ventajas aportan nuestros productos al profesional en cada fase de la gestión de los alimentos?

ARAVEN ha concentrado sus esfuerzos en la innovación en los procesos de Conservación y Manipulación de Alimentos, los más exigentes para cumplir las normas de seguridad alimentaria.

Almacenamiento y conservación

ARAVEN fue pionera en integrar una etiqueta permanente y un sistema ColorClip en sus herméticos para identificar los alimentos a conservar y evitar la contaminación cruzada. Los herméticos ARAVEN permiten conservar los alimentos con todas las garantías higiénico-alimentarias. Reducen la carga microbiana y la oxidación del alimento, prolongando la vida útil del alimento y preservando las óptimas propiedades organolépticas de los productos (color, olor, sabor, textura...). Los contenedores accesibles son ideales para garantizar el óptimo almacenamiento y la correcta conservación de los productos en diferentes condiciones de temperatura.

Manipulación y preparación:

Los productos ARAVEN favorecen a prevenir, reducir o eliminar posibles riesgos en las diferentes fases de elaboración y manipulación de alimentos.

Servicio y exposición

ARAVEN cuenta con una amplia gama de productos para el servicio y exposición de alimentos en la que se ha cuidado el diseño y la funcionalidad para responder a las necesidades tanto del personal de servicio como el de cocina.

Transporte

ARAVEN conserva los alimentos a temperatura adecuada durante el transporte, manteniendo la cadena de frío para evitar la multiplicación de microorganismos que puedan afectar a la calidad y seguridad de los alimentos.

Limpieza

Los cubos de basura ARAVEN son aliados fundamentales en la implantación de sistemas APPCC/HACCP en procesos de limpieza.



Sostenibilidad y compromiso de futuro

Todos los miembros de ARAVEN estamos comprometidos con la sostenibilidad como apuesta de futuro.

Nuestros principios fundamentales son:

- 1. Cumplir los requisitos establecidos** en cada uno de los trabajos que realizamos, coordinándolos con los de nuestros clientes y proveedores.
- 2. Prevenir la contaminación y el impacto al medio ambiente,** gestionando adecuadamente todos los aspectos derivados de nuestros procesos y actividades.
- 3. Minimizar los consumos la generación de emisiones y residuos** en los procesos de producción gestión y reciclado.
- 4. Promover nuestro compromiso medioambiental** a nuestros proveedores para hacerles partícipes de él.
- 5. Buscar la mejora continua de las actividades en marcha para el menor impacto al medioambiente.**
- 6. Hacer partícipe proactivamente a todo el personal de la empresa en el cumplimiento de los puntos anteriores y en la gestión del valor medioambiental de las actividades.**

La Política Medioambiental de ARAVEN es una responsabilidad de todos, cuenta con el total apoyo de Dirección General y su cumplimiento se considera un objetivo prioritario.

Este concepto responsabilidad no acaba en el apartado medioambiental, sino que incluye también los ejes social y económico. En ARAVEN entendemos la **Sostenibilidad como un proyecto obligatorio**. Un compromiso que como ciudadanos hemos de asumir con nuestro planeta y con nuestra sociedad actual y las próximas generaciones. Un proyecto estratégico llamado a convertirse en nuestra manera habitual de trabajar.

El respeto medioambiental es un atributo esencial de nuestro proceso de innovación. ARAVEN persigue productos duraderos y que estén elaborados con materiales y procesos eficaces y respetuosos con nuestro planeta.



La regla de las 3R



Reducir

En la fase de diseño realizamos un estudio para definir los espesores de pieza idóneos y así utilizar el mínimo material en la fabricación de la pieza, sin penalizar ni la calidad ni la funcionalidad. Analizamos los efectos medioambientales de los materiales y su posible sustitución por soluciones más verdes. Examinamos todo el proceso de producción para minimizar impactos desde la eficiencia de los procesos y la reducción de consumos.



Reutilizar

ARAVEN no desarrolla productos de usar y tirar, también llamados desechables o de un solo uso. Todos los artículos ARAVEN están pensados para una prolongada vida útil, en un entorno profesional de uso intensivo. Fomentamos el uso de productos reutilizables en todos los procesos del trabajo en hostelería con campañas de concienciación para los profesionales.



Reciclar

Todos los **productos ARAVEN Hostelería se fabrican con materiales reciclables**. Buscamos fabricar los productos con un solo material, o en su defecto intentamos **facilitar la separación de materiales y componentes** en los productos multimaterial para favorecer su reciclaje. Tenemos una estrategia de cero desperdicios con la que buscamos que los restos de materiales generados en el proceso de fabricación se aprovechen en nuestros productos o en los de nuestros colaboradores.

Sostenibilidad en las cocinas

Planteamos **soluciones de conservación para un negocio más sostenible**, con alternativas para reducir la generación de residuos por utilizar film, plástico o papel de aluminio. Nuestros contenedores llevan una etiqueta integrada y no se necesitan adhesivos adicionales para la identificación del alimento a conservar.

El ahorro de costes y la mejora continua puede darse en todos los ámbitos de la gestión, también dentro de la conservación de los alimentos. La cantidad de alimento que se tira a la basura por una mala gestión de la conservación no solo genera un problema de sostenibilidad, sino que también es un sobrecoste para el negocio.

Seguridad alimentaria

La higiene y la seguridad alimentaria es una de las grandes prioridades de los restaurantes. El canal HORECA, al igual que la industria alimentaria, debe aplicar los principios del Análisis de Peligros en Puntos Críticos de Control (APPCC / HACCP) para gestionar los riesgos y la inocuidad de los alimentos.

La seguridad alimentaria no sólo depende del estado y del tipo de proceso al que se someten los alimentos. Los materiales que se ponen en contacto con ellos juegan un papel muy importante. Los productos ARAVEN cumplen y ayudan a cumplir todas las normativas exigidas en materia higiénico-alimentaria.

En ARAVEN prestamos una especial atención a toda la reglamentación en materia higiénico-sanitaria, para tranquilidad nuestra y de nuestros clientes.

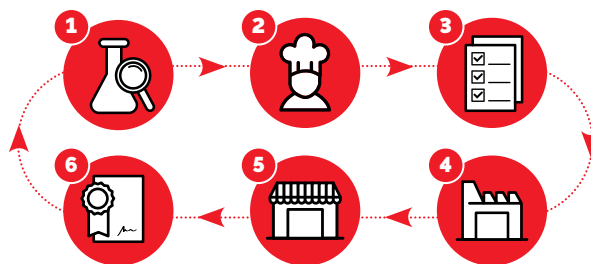

Las autoridades sanitarias revisarán que los productos utilizados en los establecimientos hosteleros cumplan con la normativa.

Los fabricantes deben certificar el cumplimiento de la normativa a sus clientes para trasladarlo a los establecimientos de hostelería.

1. Autoridades sanitarias
2. Establecimientos de restauración
3. Exigencia del cumplimiento
4. Fabricantes
5. Distribuidores de hostelería
6. Certificación del cumplimiento

La Normativa de Seguridad Alimentaria es nuestra guía de trabajo y fuente de inspiración en el desarrollo de nuevos productos.

Los productos ARAVEN, diseñados en base al CODEX Alimentarius, ayudan a los establecimientos hosteleros a aplicar Prácticas Correctas de Higiene para prevenir, reducir o eliminar posibles riesgos en las diferentes fases de elaboración, manipulación y conservación de alimentos. Estas herramientas de trabajo se han diseñado con el objetivo de reducir al mínimo el riesgo de contaminación de los productos alimenticios y están fabricados con materiales resistentes a la corrosión, fáciles de limpiar y desinfectar.

Su uso, junto con un entorno higiénico y buenas prácticas, garantiza la seguridad de los alimentos en todos los procesos desde la entrada del producto hasta su servicio. En el sector HORECA para la gestión y tratamiento de los alimentos en la cocina, se identifican las siguientes fases:



Certificados



El Sistema de Gestión de Calidad de ARAVEN S.L. está certificado según la norma ISO 9001:2015.



Inscrita en el Registro General Sanitario de Alimentos de la Agencia Española de Seguridad Alimentaria y Nutrición. R.D. 191/2011. (R.G.S.A. 39.04328/Z)



Cumplimiento de todas las normativas europeas sobre materiales y objetos destinados a entrar en contacto con alimentos.

Reglamentación Técnico-Sanitaria para materias plásticas de uso alimentario: Reg.(CE) 1935/2004 Reg. (CE) 10/2011 Reg (CE) 1907/2006 (REACH).



La totalidad de nuestros productos plásticos están fabricados con Materia Prima 100% Reciclable.

Empresa adherida al Sistema Integrado de Gestión Ecoembes para el cumplimiento de las Normativas de Envases y Residuos de Envases Directiva 94/62/CE y 2004/12/CE.



APPCC / HACCP

El Análisis de Peligros y Puntos de Control Críticos, es un proceso sistemático preventivo para garantizar la seguridad alimentaria.

Todo el equipamiento y los utensilios empleados en las zonas de conservación y manipulación de alimentos que puedan entrar en contacto con los mismos deben ser de un material que no transmita sustancias tóxicas, olores ni sabores; que no sea absorbente; resista a la corrosión y soporte repetidas operaciones de limpieza y desinfección. Las superficies deben de ser lisas y estar exentas de hoyos y grietas.

Los productos ARAVEN están diseñados con cantos redondeados de fácil limpieza, sin aristas vivas ni recovecos que puedan alojar restos de suciedad, y todos permiten el lavado en el lavavajillas. Además, incorporan elementos como el ColorClip y la etiqueta integrada de trazabilidad para mantener un elevado nivel de seguridad alimentaria y ayudar al cumplimiento de las normativas y del sistema de autocontrol.

Productos que cumplen los más altos estándares en materia de higiene y seguridad alimentarias (APPCC/HACCP), creados con la colaboración de expertos consultores en esta materia.



NSF

Fundación Nacional Sanitaria (National Sanitation Foundation). Es una organización independiente que realiza el control que satisfacen los criterios establecidos respecto al diseño y la construcción, la evaluación de los materiales y las pruebas de rendimiento. Los productos ARAVEN tienen la Certificación NSF y por tanto están contenidos en las listas de productos NSF. www.nsf.org/Certified/Food/

La marca NSF asegura a los consumidores, minoristas y reguladores que los productos han sido analizados rigurosamente y cumplen con los requisitos de todos los estándares .



Migraciones

La Normativa de Migraciones establece limitaciones a las migraciones de sustancias en materiales plásticos y es aplicable a materiales plásticos en contacto con los alimentos. ARAVEN cumple con todas las Normativas de Migraciones: Directiva 2005/79/EU, Directiva 2007/19/EU, Directiva 2008/39/ EU y Directiva 2011/10/UE.



Trazabilidad

Se entiende a la capacidad de seguir el recorrido de los alimentos u objetos destinados a estar en contacto con ellos desde su producción hasta su consumo, cubriendo todos los pasos de la cadena de suministro. Facilitamos herramientas para el cumplimiento de la Normativa de Trazabilidad Reg (CE) 852/2004 y Reg (CE) 178/2002 referentes a los alimentos. La etiqueta incorporada en los contenedores de alimentos ARAVEN y el rotulador HORECA marker son el único sistema integral que asegura unas Prácticas Correctas de Higiene y ayudan al cumplimiento de estas normativas.



ARAVEN incorpora en sus productos sistemas de identificación para el cumplimiento de la Normativa Reg (CE) 1935/2004 referente a los utensilios en contacto con alimentos.















Medidas GastroNorm

La industria de equipos de restauración utiliza los productos de tamaño estándar para permitir la adaptación entre todos los equipos, aparatos y contenedores dentro de la cocina, cámaras frigoríficas y áreas de exposición. La normativa GN permite optimizar el espacio durante los distintos circuitos de conservación, manipulación y cocción. Simplifica la organización interna del restaurante y asegura una compatibilidad entre diferentes sistemas y alojamientos tales como mesas de trabajo, equipos de transporte o mesas de exposición.

ARAVEN adopta el estándar de medidas GastroNorm como la norma principal de tamaños para ser utilizados en sus productos. Norma EN 631.1 del Comité de Normalización de la Comisión Europea.

Te ayudamos a elegir la medida y capacidad de cubeta GastroNorm.

		65mm					100mm				
		PP	ABS	ABS	PC	PC	PP	ABS	ABS	PC	PC
											
0,5L - 4L	GN 1/9	03020 0,6L	74010 0,6L	44010 0,6L	-	94010 0,6L	03021 1L	74011 0,9L	44010 0,6L	-	94011 0,9L
	GN 1/6	03023 1,1L	07796 1L	-	09796 1L	94015 1L	03024 1,7L	07797 1,5L	47797 1,5L	09797 1,5L	94016 1,6L
	GN 1/4	03026 1,8L	07816 1,6L	-	09816 1,6L	94019 1,7L	03027 2,8L	07817 2,6L	-	09817 2,6L	94020 2,6L
	GN 1/3	03029 2,5L	07808 2,35L	-	09808 2,35L	94025 2,4L	03030 4L	07819 3,7L	47819 3,7L	09819 3,7L	94026 3,7L
4L - 9L	GN 1/4	-	-	-	-	-	-	-	-	-	-
	GN 1/3	-	-	-	-	-	-	-	-	-	-
	GN 1/2	03032 4L	07821 3,9L	-	09821 3,9L	94034 4L	03033 6,5L	07822 5,95L	47822 5,95L	09822 5,95L	94035 6,2L
	GN 2/4	-	-	-	-	-	-	-	-	-	94051 5,7L
	GN 1/1	03044 8,3L	07826 8,35L	47826 8,35L	09826 8,35L	94058 8,6L	-	-	-	-	-
9L - 15L	GN 1/2	-	-	-	-	-	-	-	-	-	-
	GN 2/3	-	-	-	-	-	03469 9L	-	-	-	-
	GN 2/4	-	-	-	-	-	-	-	-	-	-
	GN 1/1	-	-	-	-	-	03036 13,7L	07827 13L	47827 13L	09827 13L	94059 13,4L
15L - 25L	GN 2/3	-	-	-	-	-	-	-	-	-	-
	GN 1/1	-	-	-	-	-	-	-	-	-	-



- GN 1/9: 176x108 mm
- GN 1/6: 176x162 mm
- GN 1/4: 265x162 mm
- GN 1/3: 325x176 mm
- GN 1/2: 325x265 mm
- GN 2/3: 354x325 mm
- GN 2/4: 530x162 mm
- GN 1/1: 530x325 mm

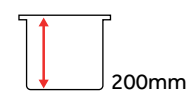
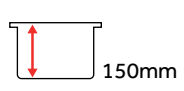
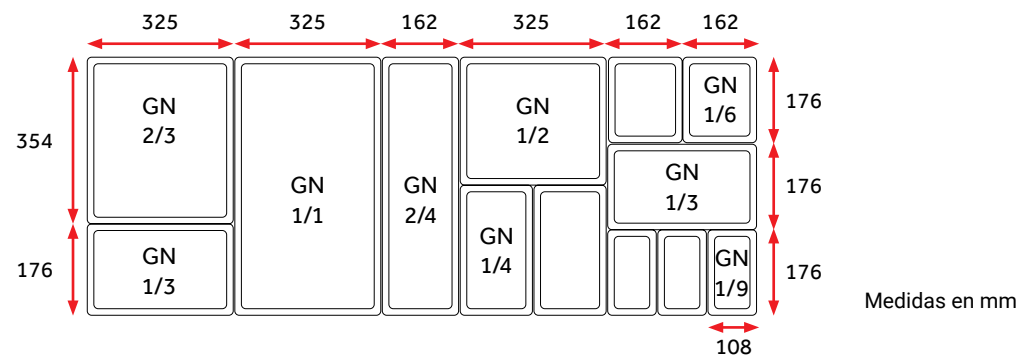

Capacity	GN Code	150mm Depth					200mm Depth				
		PP	ABS	ABS	PC	PC	PP	ABS	ABS	PC	PC
0,5L - 4L	GN 1/9	03022 1,5L	-	-	-	94012 1,2L	-	-	-	-	-
	GN 1/6	03025 2,6L	07798 2,15L	47798 2,15L	09798 2,15L	94017 2,3L	-	-	-	-	-
	GN 1/4	-	07818 3,7L	-	09818 3,7L	94021 3,8L	-	-	-	-	-
	GN 1/3	-	-	-	-	-	-	-	-	-	-
4L - 9L	GN 1/4	03028 4,3L	-	-	-	-	-	-	-	-	-
	GN 1/3	03031 6L	07820 5,4L	47820 5,4L	09820 5,4L	94027 5,5L	-	07831 6,7L	-	09831 6,7L	-
	GN 1/2	-	-	-	-	94036 8L	-	-	-	-	-
	GN 2/4	-	-	-	-	-	-	-	-	-	-
	GN 1/1	-	-	-	-	-	-	-	-	-	-
9L - 15L	GN 1/2	03034 10L	07823 9L	47823 9L	09823 9L	-	03035 12,5L	07834 11,35L	47835 11,35L	09834 11,35L	94037 11,8L
	GN 2/3	00470 14L	-	-	-	-	-	-	-	-	-
	GN 2/4	-	-	-	-	94052 10,8L	-	-	-	-	-
	GN 1/1	-	-	-	-	-	-	-	-	-	-
15L - 25L	GN 2/3	-	-	-	-	-	00471 19L	-	-	-	-
	GN 1/1	03037 20,5L	07828 19,6L	47828 19,6L	09828 19,6L	94060 20L	03038 27,5L	07835 26,1L	47835 26,1L	09835 16,1L	94061 26,2L

Materiales

Polipropileno PP

Permite la identificación del alimento.
El equilibrado balance de características de resistencia-peso, la rigidez y comportamiento de temperaturas hacen de este plástico la solución más extendida entre los profesionales hosteleros para la conservación de alimentos.

Alta resistencia al calor: 95°C. Buen comportamiento a bajas temperaturas -40°C. Buen balance de rigidez-tenacidad. Robustez, higiene, durabilidad...

Permite el lavado en el lavavajillas.
Buena resistencia superficial y química.
Poca absorción de agua.

Productos libres de BPA.



+95°C | +203°F
-40°C | -40°F



Policarbonato PC

Alta resistencia al impacto.
Muy resistente, durabilidad. Óptimo comportamiento a muy bajas temperaturas soportando en altas incluso baño maría. Máxima transparencia para una rápida identificación del alimento y su estado.

Permite el lavado en el lavavajillas.
Gran estabilidad dimensional.
Muy baja absorción de humedad.
Estabilidad a agentes químicos, no colorea.



+99°C | +210°F
-40°C | -40°F



Acrilonitrilo butadieno estireno ABS

Alta resistencia al impacto.
Muy resistente, durabilidad. Óptimo comportamiento a bajas y medias temperaturas. Máxima transparencia para una rápida identificación del alimento y su estado.

Permite el lavado en el lavavajillas.
Gran estabilidad dimensional.
Muy baja absorción de humedad.
Estabilidad a agentes químicos, no colorea.

Productos libres de BPA.



+80°C | +176°F
-40°C | -40°F



Polietileno HDPE

Sin colorante tiene color blanco.

Buena resistencia al impacto, alta resistencia a la corrosión. Buen comportamiento en congelación e impide el paso de la humedad. Sin ser un material rígido proporciona una buena estabilidad dimensional.

Permite el lavado en el lavavajillas.
Productos libres de BPA.



+90°C | +194°F
-40°C | -40°F



Polietileno LDPE

Sin colorante tiene aspecto translúcido.

Muy flexible. Es blando y elástico: límite elástico muy alto recupera la forma tras deformación.
Buenas propiedades mecánicas y ópticas.

Permite el lavado en el lavavajillas.
Productos libres de BPA.



+90°C | +194°F
-40°C | -40°F



Silicona

Es un polímero sintético utilizado en diferentes utensilios, envases y moldes para la cocina.

No dejan residuos
No se desgasta. No envejece.
No es corrosiva. No se oxida como el metal.
No se deforma, recupera su estado inicial.
No se rompe como el cristal.
No altera el sabor de la comida. Insípida.
No actúa como soporte para el desarrollo de bacterias. Inocuo
Impermeabilidad. Repele el agua.
No utiliza utensilios punzantes.
Resistencia a temperaturas extremas.
Permite el lavado en el lavavajillas.
Productos libres de BPA.



+200°C | +392°F
-40°C | -40°F



Estireno Acrilonitrilo SAN

Material muy transparente cuando no va coloreado y lo que dota a la pieza de una gran visibilidad y brillo.

Cuando es mezclado con colorante se consigue además una gran presencia.

Es rígido pero más frágil que el resto de materiales.
Permite el lavado en el lavavajillas.
Productos libres de BPA.



+90°C | +194°F
-40°C | -40°F



Poliestireno PS

Material de excelente presencia, brillo y acabado superficial.

Permite el lavado en el lavavajillas.
Productos libres de BPA.



+90°C | +194°F
-40°C | -40°F



Otros materiales:

Polipropileno expandido:

+120°C | +248°F
-40°C | -40°F



Poliamida nylon:

+70°C | +158°F
-40°C | -40°F



Polimetilmetacrilato:

+70°C | +158°F
-40°C | -40°F



Aluminio:

+150°C | +302°F
-25°C | -13°F





Conservación

16 - 93



Manipulación

94 - 125



Servicio y exposición

126 - 161



Transporte

162 - 171



Limpieza

172 - 181



Datos logísticos

182 - 207

Herméticos de PP	022 - 025	Tapas herméticas y de apoyo	052 - 055	Contenedores accesibles	072 - 075
Polipropileno Basic	026 - 031	Sistema de identificación	056 - 057	Contenedores cuadrados	076 - 079
Cubetas y herméticos de ABS	032 - 035	Antialérgenos	058 - 061	Otras cubetas	080 - 081
Cubetas de ABS mesa fría	036 - 039	Contenedores GastroNorm 2/1	062 - 065	Carro GastroNorm 1/1	082 - 083
Cubetas y herméticos de PC	040 - 043	Sistemas de descongelación	066 - 067	Torres de cubetas GastroNorm	084 - 087
Cubetas en PC	044 - 047	Cubeta 60 x 40	068 - 069	Estanterías	088 - 093
Cubetas caladas PC	048 - 050	Carro 60 x 40	070		
Rejillas GastroNorm	051	Plataforma extensible	071		

Tablas de corte	096 - 099	Dosificador de 3 puntas	108 - 109	Grifo y Jarra medidora	116 - 117
Dosificador de salsas	100 - 103	Dispensadores de grano y aceite	110	Cubetas sin tapa	118 - 121
Mini dosificadores	104 - 105	Organizadores de dosificadores	111	Bowls y escurridores	122 - 124
Dosificador de salsas antigoteo	106 - 107	Dispensador para salsas	112 - 115	Tapas de silicona redondas	125

Bandejas de 5 compartimentos	128 - 130	Expobandeja y expovitrinas GN	138	Jarras	152 - 154
Carro de bandejas 5 compartimentos	131	Cubreplatos y Bowls	139	Servicio de mesa	155 - 156
Bandejas de servicio y exposición	132 - 134	Vajilla catering	140 - 143	Portacubiertos	157
Carro de bandejas	135	Vasos, copas y jarras	144 - 149	Carros de servicio y accesorios	158 - 159
Bandejas de exposición	136 - 137	Accesorios de Buffet	150 - 151	Organizadores	160 - 161

Armario isotérmico GastroNorm	164 - 165	Isotérmico para líquidos	167	Cubetas con tapa	168 - 169
Armario isotérmico GN HDPE	166	Plataforma GastroNorm	167	Food Bacs	170 - 171

Cubos de basura	174 - 179	Limpieza e higiene	180	Ordenación multiusos	181
-----------------	-----------	--------------------	-----	----------------------	-----



Conservación

Un buen contenedor de conservación es un elemento imprescindible en una cocina, las propiedades de un buen alimento pueden deteriorarse por no conservarlo en el recipiente adecuado. Una correcta conservación de los alimentos cumplirá un doble objetivo:

1. Asegurar una calidad higiénico-sanitaria óptima.
2. Reducir el nivel de mermas por deterioro de los mismos.

Una correcta conservación de alimentos ricos en proteína es clave por varios motivos:

- Garantiza la higiene y seguridad alimentaria y la salud de los comensales, cumplimiento de la normativa. Evita riesgos

de contaminaciones bacteriológicas, que en el caso de las proteínas pueden ser de gravedad.

- Reduce la merma de este tipo de alimentos, que generalmente son los más costosos de los almacenados en una cocina.

- Garantiza la calidad de las elaboraciones y su resultado final. Mantiene las propiedades organolépticas de los alimentos (color, sabor, textura...) asegurando que lleguen al cliente en perfectas condiciones tras su elaboración.

Aspectos como la optimización del espacio en conservación, el control de fechas de envasado, la elaboración y la pre-elaboración, o la identificación de los alimentos resultarán claves para la implantación del sistema APPCC/HACCP y la gestión eficiente.



En este aspecto ARAVEN proporciona herramientas como:

Estanterías de materiales no porosos e inalterables en condiciones de humedad: plástico y aluminio anodizado. Baldas perforadas para facilitar la circulación del aire.

Contenedores con gran variedad de capacidades para ajustar el tamaño del envase a la cantidad habitual de consumo.

Métodos para una correcta colocación de los alimentos en función de su grupo y naturaleza que evitan contaminaciones cruzadas.

Contenedores con etiqueta permanente de trazabilidad, de modo que podamos registrar la procedencia del alimento, su elaboración, la fecha de conservación...

Sistemas que facilitan una ordenada rotación de los alimentos: lo primero que entra - lo primero que sale.

Sistemas de separación de exudado para una correcta conservación de carnes y pescados crudos.

Contenedores provistos de tapa que eviten contaminaciones cruzadas entre distintos tipos de alimentos. Este sistema es más sostenible que utilizar film plástico o papel de aluminio. Además, evita que el alimento se reseque y que absorba o libere olores que puedan penalizar su calidad.

Los productos ARAVEN están provistos de elementos orientados a la excelencia operativa que facilitan la gestión de la materia prima almacenada asegurando la óptima conservación de las propiedades organolépticas de estos alimentos.



Etiqueta permanente IML

Identificar los contenedores utilizados para la conservación y almacenamiento con la información necesaria que permita garantizar la trazabilidad de todos los productos.

Los contenedores ARAVEN cuentan con **etiqueta permanente de trazabilidad integrada** en la cubeta, de modo que permite identificar el contenido y preservar la información asociada a su origen. Podemos registrar la procedencia del alimento, tipo de producto, elaboración, condiciones de conservación, fecha de conservación, etc.

La etiqueta permanente incorporada en los contenedores de alimentos ARAVEN es el **único sistema integral que asegura unas prácticas correctas de higiene**. Permite al profesional de la cocina identificar el contenido y preservar la información asociada a su origen escribiendo datos como: la procedencia del alimento, su elaboración, la fecha de conservación, etc.

En conservación, el control de fechas de envasado y la identificación de los alimentos resultan clave para la implantación del sistema de APPCC/HACCP y la gestión eficiente. Con un mayor orden se consigue un mayor control de las materias primas, lo que implica una reducción de mermas y por lo tanto un ahorro en coste.

Ahorro: No requiere de la incómoda y costosa reposición de la etiqueta. No se necesita pegar y despegar etiquetas de papel.

Facilidad de uso y comodidad: es tan sencillo como escribir sobre la etiqueta con el rotulador ARAVEN la información detallada en la etiqueta.

Higiene: Etiqueta integrada no deja restos y queda como nueva lavado tras lavado en el lavavajillas.



Sistema FIFO

Independientemente de la temperatura de conservación (refrigeración, congelación o ambiente) se recomienda gestionar los alimentos según el sistema FIFO/PEPS (First in, First out /Primero en Entrar, Primero en Salir), ordenados y separados en contenedores apropiados.

ARAVEN dispone de contenedores que cuentan con sistemas que facilitan una ordenada rotación de los alimentos (FIFO/PEPS).

Este sistema permite que lo primero que entró en tu almacén o cámara de conservación sea lo primero que consumas evitando así mermas no deseadas.

Los colorclip de ARAVEN en colores rojo, amarillo y verde te ayudan a clasificar los alimentos según su entrada y salida.





ColorClip

7 Colorclips que facilitan la gestión de los alimentos dentro de la cocina en base a distintos criterios como:

Clasificación por tipología de alimento: Los Contenedores ARAVEN, gracias a su identificación ColorClip, ayudan a prevenir la Contaminación Cruzada, asegurando que el contenido de este recipiente va a ser siempre de la misma naturaleza: aves, carnes rojas, verduras/frutas o pescados. Dos nuevos colores se incorporan al sistema de identificación blanco para los lácteos y marrón para carnes elaboradas y embutidos.



Pescados



Aves



Carnes Rojas



Embutidos y elaborados



Frutas y verduras



Lácteos



Alergias e intolerancias

Clasificación por fechas: 7 Colorclips identificativos permiten clasificar la elaboración de cada día de la semana.



Lunes



Martes



Miércoles



Jueves



Viernes



Sábado



Domingo



Clasificación operativa en un restaurante: Agilizan la identificación del contenido y el acceso al mismo. Reduciendo los tiempos de aprovisionamiento de las estaciones de trabajo y mesas de preparación. Para ayudarte en la elaboración de los menús y ajustar al máximo los tiempos de respuesta.

Siete colores para identificar las materias primas relacionadas con un determinado menú. Ejemplo:



Clasificación por línea operativa y áreas de trabajo por proceso: Sistemas de clasificación y organización de las proteínas almacenadas en base a criterios de fecha de conservación, procesado, descongelación, etc.





araven

GASTRONORM
-MPC-MPT +MPC+MPT

Prod. Item: _____

Fecha Dat.: _____

Empl.: _____

Caducidad Use by: _____

Trazabilidad Traceability: _____

AM

PM



araven

GASTRONORM
-MPC-MPT +MPC+MPT

Prod. Item: _____

Fecha Dat.: _____

Empl.: _____

Caducidad Use by: _____

Trazabilidad Traceability: _____

AM

PM



araven

Prod. Item: _____

Fecha Dat.: _____

Empl.: _____

Caducidad Use by: _____

Trazabilidad Traceability: _____



araven

GASTRONORM
-MPC-MPT +MPC+MPT

Prod. Item: _____

Fecha Dat.: _____

Empl.: _____

Caducidad Use by: _____

Trazabilidad Traceability: _____



Herméticos de polipropileno

+95°C | +203°F
-40°C | -40°F



Los herméticos ARAVEN permiten conservar los alimentos con todas las garantías higiénico-alimentarias evitando su deterioro nocivo y protegiéndolos de la contaminación cruzada.

Los contenedores ARAVEN, gracias a su cierre hermético, alargan hasta un 25% la vida útil del alimento*.

Alarga la vida útil del alimento:

1. Selecciona la medida GastroNorm del contenedor ARAVEN que más se adecúe al volumen de materia prima a conservar. Contra más alimento contenga el recipiente menor oxígeno tendrás en el interior del mismo.
2. Cuando cierres el contenedor presiona en el centro de la tapa para extraer parte del aire que hay en el interior del mismo. **Presionamos la tapa** en el centro y vamos cerrándola en la dirección de la salida del aire. De esta manera **extraemos parcialmente el aire** para una mejor conservación del alimento.

La tapa va provista de un canal que permite extraer parcialmente el aire del interior del contenedor lo que reduce la oxidación del alimento.



*Estudio realizado por Grupo de Investigación en Alimentos de Origen Vegetal Universidad de Zaragoza.

Herméticos de polipropileno



Hermético: Doble Cierre hermético para una total protección del alimento. La tapa esta fabricada en LDPE material más flexible que permite un correcto ajuste a la base.

Etiqueta integrada: La etiqueta Permanente permite al profesional de la cocina identificar el contenido y preservar la información asociada a su origen ayudando a cumplir con la Normativa de Trazabilidad Reg (CE) 852/2004 y Reg (CE) 178/2002 referentes a los alimentos.

ColorClip: Código de color para evitar las contaminaciones cruzadas. Los Contenedores ARAVEN, gracias a su identificación ColorClip, ayudan a prevenir la Contaminación Cruzada, asegurando que el contenido de este recipiente va a ser siempre de la misma naturaleza: aves, carnes rojas, verduras/frutas o pescados.



Escala de contenido: Regleta de medición e indicador de medida GastroNorm.

Fácil apertura: El contenedor va provisto de un tirador en la tapa que facilita su apertura.

Medidas GastroNorm: Productos diseñados y fabricados según dimensiones y especificaciones establecidos en la Norma EN 631.1. Selecciona la medida GastroNorm del contenedor ARAVEN que más se adecúe al volumen de materia prima a conservar. Contra más alimento contenga el recipiente menor oxígeno tendrás en el interior del mismo.

Apilables con tapa y encajables en vacío.

Fácil limpieza: Cantos redondeados. Su especial diseño evita que se acumulen restos y facilita la limpieza.



3020 3021 3022 3023 3024 3025 3026 3027 3028 3029 3030
 3031 3032 3033 3034 3035 3036 3037 3038 3044 470 471 3469

+95°C | +203°F
 -40°C | -40°F



65mm

100mm

150mm

200mm

GN 1/9
 176x108 mm



Ref. **03020** / 0,6 L



Ref. **03021** / 1 L



Ref. **03022** / 1,5 L

GN 1/6
 176x162 mm



Ref. **03023** / 1,1 L



Ref. **03024** / 1,7 L



Ref. **03025** / 2,6 L

GN 1/4
 265x162 mm



Ref. **03026** / 1,8 L



Ref. **03027** / 2,8 L



Ref. **03028** / 4,3 L

GN 1/3
 325x176 mm



Ref. **03029** / 2,5 L



Ref. **03030** / 4 L



Ref. **03031** / 6 L

GN 1/2
 325x265 mm



Ref. **03032** / 4 L



Ref. **03033** / 6,5 L



Ref. **03034** / 10 L



Ref. **03035** / 12,5 L

GN 2/3
 354x325 mm



Ref. **03469** / 9 L



Ref. **00470** / 14 L



Ref. **00471** / 19 L

GN 1/1
 530x325 mm



Ref. **03044** / 8,3 L



Ref. **03036** / 13,7 L



Ref. **03037** / 20,5 L



Ref. **03038** / 27,5 L

Rotulador
 HORECA
 Pág. 57



Rejillas
 GastroNorm
 Pág. 51





PANES
27 Q 25 Alca

Cubetas de Polipropileno Basic



Con el grabado superficial en pieza y usando el rotulador ARAVEN Horeca Marker para escribir sobre esta parte de la cubeta, podemos identificar el contenido preservando la información asociada a su origen o su manipulación.

Las cubetas van provistas en su borde superior de unos grabados con los días de la semana y hora, para que ubicadas en una mesa de manipulación el operario pueda conocer la hora y día de caducidad del alimento marcadas durante su elaboración. La regleta de medición en las cubetas permite controlar la cantidad de los líquidos contenidos.

Cubetas perforadas de Polipropileno Basic

NSF _4073 _4075
_4076 _4078



+95°C | +203°F
-40°C | -40°F



6x

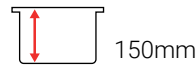
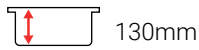

GN 1/6
176x162mm



Ref. **04073** / 1,9L



+



Ref. **04017** / 2,3L



GN 1/3
325x176mm



Ref. **04075** / 4,6L



+



Ref. **04027** / 5,5L



GN 1/2
325x265mm



Ref. **04076** / 7,8L



+



Ref. **04036** / 8L

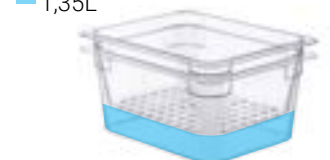

GN 1/1
530x325mm



Ref. **04078** / 17,2L



+



Ref. **04060** / 20L



Cubetas de Polipropileno Basic



+95°C | +203°F

-40°C | -40°F



PP



_4010 _4011 _4012 _4015 _4016 _4017 _4019 _4020 _4021 _4025
_4026 _4027 _4034 _4035 _4036 _4037 _4058 _4059 _4060 _4061

6x

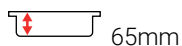

65mm



100mm



150mm

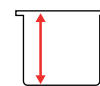

200mm

GN 1/9
176x108mm



Ref. **04010** / 0,6L



Ref. **04011** / 0,9L



Ref. **04012** / 1,2L

GN 1/6
176x162mm



Ref. **04015** / 1L



Ref. **04016** / 1,6L



Ref. **04017** / 2,3L

GN 1/4
265x162mm



Ref. **04019** / 1,7L



Ref. **04020** / 2,6L



Ref. **04021** / 3,8L

GN 1/3
325x176mm



Ref. **04025** / 2,4L



Ref. **04026** / 3,7L



Ref. **04027** / 5,5L

GN 1/2
325x265mm



Ref. **04034** / 4L



Ref. **04035** / 6,2L



Ref. **04036** / 8L



Ref. **04037** / 11,8L

GN 1/1
530x325mm



Ref. **04058** / 8,6L



Ref. **04059** / 13,4L



Ref. **04060** / 20L



Ref. **04061** / 26,2L

48x

Horeca
Marker



Ref. **00393** / 138x19 mm

Tapa de apoyo universal de Polipropileno Basic



04013 04018
04022 04029
04038 04062



+95°C | +203°F
-40°C | -40°F



Permite tapar la mayor parte de las Cubetas GastroNorm en diferentes materiales. Provista de un asa para facilitar su apertura. Apilamiento con tapa, registro de base y tapa. Versión con muesca para alojar la cuchara o utensilio en la zona de servicio con la tapa posicionada en la cubeta.

6x



Ref. **04013** · GN 1/9
176x108xh13 mm



Ref. **04018** · GN 1/6
176x162xh27 mm



Ref. **04022** · GN 1/4
265x162xh27 mm



Ref. **04029** · GN 1/3
325x176xh27 mm



Ref. **04038** · GN 1/2
325x265xh27 mm



Ref. **04062** · GN 1/1
530x325xh27 mm

Versión con muesca



6x



Ref. **34013** · GN 1/9
176x108xh13 mm



Ref. **34018** · GN 1/6
176x162xh27 mm



Ref. **34022** · GN 1/4
265x162xh27 mm



Ref. **34029** · GN 1/3
325x176xh27 mm



Ref. **34038** · GN 1/2
325x265xh27 mm



Ref. **34062** · GN 1/1
530x325xh27 mm

Tapa de conservación de Polipropileno Basic

NSF _7390 _7391
_7392 _7393
_7394 _7395



+95°C | +203°F
-40°C | -40°F



NSF 0



Ref. **07390** · GN 1/9
176x108xh20 mm



Ref. **07391** · GN 1/6
176x162xh22 mm



Ref. **07392** · GN 1/4
265x162xh22 mm



Ref. **07393** · GN 1/3
325x176xh22 mm



Ref. **07394** · GN 1/2
325x265xh22 mm



Ref. **07395** · GN 1/1
530x325xh22 mm

6x

ColorClip

7 Colorclips que facilitan la gestión de los alimentos dentro de la cocina en base a distintos criterios.

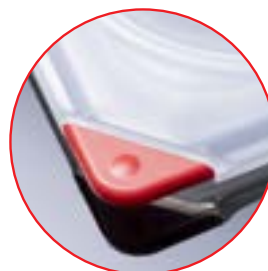

16x
Ref. **03019**
165x100xh6 mm
Set 14 (2 x color)



Cubetas y herméticos de ABS

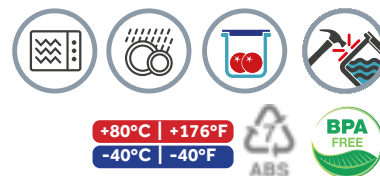

La línea de cubetas y herméticos fabricada en ABS, un material alternativo al policarbonato, libre de BPA que ofrece una alta resistencia al impacto. El color azul que no distorsiona la identificación del contenido, ofrece una máxima transparencia para una rápida identificación del alimento y su estado.



Etiqueta integrada: La etiqueta Permanente permite al profesional de la cocina identificar el contenido y preservar la información asociada a su origen ayudando a cumplir con la Normativa de Trazabilidad Reg (CE) 852/2004 y Reg (CE) 178/2002 referentes a los alimentos.

Versatilidad: Permite tapar cubeta con cubeta. Se puede cerrar cubeta con cubeta para adaptarse a la capacidad que se necesita en cada momento.

Hermeticidad: Tapa de bi-inyección material con junta de caucho para asegurar la máxima protección de los alimentos incluso en cubetas grandes.



Fácil limpieza: Cantos redondeados. Su especial diseño evita que se acumulen restos y facilita la limpieza.

Escala de contenido: Regleta de medición e indicador de medida GastroNorm

Medidas GastroNorm: Productos diseñados y fabricados según dimensiones y especificaciones establecidos en la Norma EN 631.1. Selecciona la medida GastroNorm del contenedor ARAVEN que más se adecúe al volumen de materia prima a conservar. Contra más alimento contenga el recipiente menor oxígeno tendrás en el interior del mismo.

Ergonomía: Su borde ergonómico facilita el manejo de la cubeta.

Cubetas y herméticos de ABS



65 mm

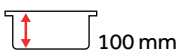

100 mm

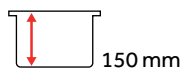

150 mm

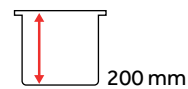

200 mm

GN 1/9
176x162 mm



Ref. **74010** / 0,6 L



Ref. **74011** / 0,9 L

GN 1/6
176x162 mm



Ref. **07796** / 1 L



Ref. **07797** / 1,5 L



Ref. **07798** / 2,15 L

GN 1/4
265x162 mm



Ref. **07816** / 1,6 L



Ref. **07817** / 2,6 L



Ref. **07818** / 3,7 L

GN 1/3
325x176 mm



Ref. **07808** / 2,35 L



Ref. **07819** / 3,7 L



Ref. **07820** / 5,4 L



Ref. **07831** / 6,7 L

GN 1/2
325x265 mm



Ref. **07821** / 3,9 L



Ref. **07822** / 5,95 L



Ref. **07823** / 9 L



Ref. **07834** / 11,35 L

GN 1/1
530x325 mm



Ref. **07826** / 8,35 L



Ref. **07827** / 13 L



Ref. **07828** / 19,6 L



Ref. **07835** / 26,1 L

Cubeta perforada

Para una perfecta conservación permite la separación del exudado del propio alimento. Otros usos: escurridor de pastas y verduras.

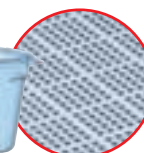
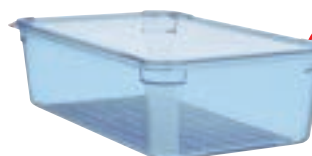

Ref. **07825** / 17,5 L



_4010 _4011 _796 _797 _798 _808 _816 _817 _818
 _819 _820 _821 _822 _823 _825 _826 _827 _828
 _831 _834 _835
 04014 09582 09583 09854 09855 09856



+80°C | +176°F
 -40°C | -40°F



NSF 7/07

65 mm

100 mm

150 mm

200 mm

GN 1/9
 176x108 mm



Ref. **77784** / 0,4 L



Ref. **77785** / 0,7 L

GN 1/6
 176x162 mm



Ref. **07781** / 0,75 L



Ref. **07782** / 1,25 L



Ref. **07783** / 1,9 L

GN 1/4
 265x162 mm



Ref. **07767** / 1,2 L



Ref. **07768** / 2,2 L



Ref. **07769** / 3,3 L

GN 1/3
 325x176 mm



Ref. **07770** / 1,65 L



Ref. **07771** / 3 L



Ref. **07772** / 4,7 L



Ref. **07786** / 6 L

GN 1/2
 325x265 mm



Ref. **07773** / 2,8 L



Ref. **07774** / 4,85 L



Ref. **07775** / 7,9 L



Ref. **07776** / 10,25 L

GN 1/1
 530x325 mm



Ref. **07777** / 6,25 L



Ref. **07778** / 10,9 L



Ref. **07779** / 17,5 L



Ref. **07780** / 24 L

Rotulador
 HORECA
 Pág. 57



Rejillas
 GastroNorm
 Pág. 51



Tapas
 Herméticas
 Pág. 52-53



Tapas
 de apoyo
 Pág. 54-55





Cubetas de ABS mesa fría



Gama de cubetas GastroNorm de ABS (BPA FREE) con etiqueta integrada para la exposición de alimento en mesa fría y correcta conservación en la cámaras.

En la parte Operativa permite la creación de "espejos" entre áreas de manipulación/mesa frías y de conservación/timbres o armarios fríos para facilitar la preparación, lotificación y el servicio. Ajuste del contenedor al tipo de alimento que contiene y al lote de producción o consumo.



Cubetas de ABS mesa fría



Etiqueta integrada: La etiqueta Permanente permite al profesional de la cocina identificar el contenido y preservar la información asociada a su origen ayudando a cumplir con la Normativa de Trazabilidad Reg (CE) 852/2004 y Reg (CE) 178/2002 referentes a los alimentos.

Versatilidad: Permite tapar cubeta con cubeta. Se puede cerrar cubeta con cubeta para adaptarse a la capacidad que se necesita en cada momento.

Hermeticidad: Tapa de bi-inyección material con junta de caucho para asegurar la máxima protección de los alimentos incluso en cubetas grandes.



Fácil limpieza: Cantos redondeados. Su especial diseño evita que se acumulen restos y facilita la limpieza.

Ergonomía: Su borde ergonómico facilita el manejo de la cubeta.

Escala de contenido: Regleta de medición e indicador de medida GastroNorm

Medidas GastroNorm: Productos diseñados y fabricados según dimensiones y especificaciones establecidos en la Norma EN 631.1. Selecciona la medida GastroNorm del contenedor ARAVEN que más se adecúe al volumen de materia prima a conservar. Contra más alimento contenga el recipiente menor oxígeno tendrás en el interior del mismo.



_4010 _4011 _797 _798 _819 _820 _822
 _823 _826 _827 _828 _834 _835

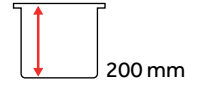
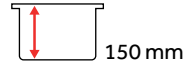
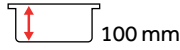
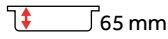

GN 1/9
176x108 mm



Ref. **44010** / 0,6 L



Ref. **44011** / 0,9 L

GN 1/6
176x162 mm



Ref. **47797** / 1,5 L



Ref. **47798** / 2,15 L

GN 1/3
325x176 mm



Ref. **47819** / 3,7 L



Ref. **47820** / 5,4 L

GN 1/2
325x265 mm



Ref. **47822** / 5,95 L



Ref. **47823** / 9 L



Ref. **47834** / 11,35 L

GN 1/1
530x325 mm



Ref. **47826** / 8,35 L



Ref. **47827** / 13 L



Ref. **47828** / 19,6 L



Ref. **47835** / 26,1 L

Portaminas
BLANCO
Pág. 57



Rejillas
GastroNorm
Pág. 51



Tapas
Herméticas
Pág. 52-53



Tapas
de apoyo
Pág. 54-55





Cubetas y herméticos de policarbonato



Etiqueta integrada: La etiqueta Permanente permite al profesional de la cocina identificar el contenido y preservar la información asociada a su origen ayudando a cumplir con la Normativa de Trazabilidad Reg (CE) 852/2004 y Reg (CE) 178/2002 referentes a los alimentos.

Versatilidad: Permite tapar cubeta con cubeta. Se puede cerrar cubeta con cubeta para adaptarse a la capacidad que se necesita en cada momento.

Hermeticidad: Tapa de bi-inyección material con junta de caucho para asegurar la máxima protección de los alimentos incluso en cubetas grandes.



Fácil limpieza: Cantos redondeados. Su especial diseño evita que se acumulen restos y facilita la limpieza.

Escala de contenido: Regleta de medición e indicador de medida GastroNorm

Ergonomía: Su borde ergonómico facilita el manejo de la cubeta.

Medidas GastroNorm: Productos diseñados y fabricados según dimensiones y especificaciones establecidos en la Norma EN 631.1. Selecciona la medida GastroNorm del contenedor ARAVEN que más se adecúe al volumen de materia prima a conservar. Contra más alimento contenga el recipiente menor oxígeno tendrás en el interior del mismo.

Cubetas y herméticos de policarbonato

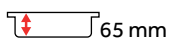

65 mm

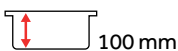

100 mm

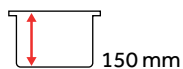

150 mm

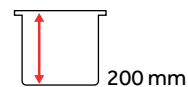

200 mm

GN 1/6
176x162 mm



Ref. **09796** / 1 L



Ref. **09797** / 1,5 L



Ref. **09798** / 2,15 L

GN 1/4
265x162 mm



Ref. **09816** / 1,6 L



Ref. **09817** / 2,6 L



Ref. **09818** / 3,7 L

GN 1/3
325x176 mm



Ref. **09808** / 2,35 L



Ref. **09819** / 3,7 L



Ref. **09820** / 5,4 L



Ref. **09831** / 6,7 L

GN 1/2
325x265 mm



Ref. **09821** / 3,9L



Ref. **09822** / 5,95 L



Ref. **09823** / 9 L



Ref. **09834** / 11,35 L

GN 1/1
530x325 mm



Ref. **09826** / 8,35 L



Ref. **09827** / 13 L



Ref. **09828** / 19,6 L



Ref. **09835** / 26,1 L

Cubeta perforada

Para una perfecta conservación permite la separación del exudado del propio alimento. Otros usos: escurridor de pastas y verduras.



Ref. **09825** / 17,5 L



__796 __797 __798 __808 __816 __817 __818 __819 __820
 __821 __822 __823 __824 __825 __826 __827 __828 __829
 __831 __834 __835

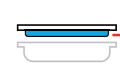

+99°C +99°F
 -40°C -40°F



NSF 09

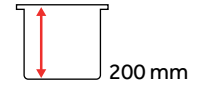
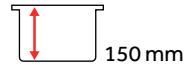
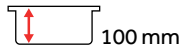
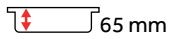

GN 1/6
 176x162 mm



Ref. **09781** / 0,75 L



Ref. **09782** / 1,25 L



Ref. **09783** / 1,9 L

GN 1/4
 265x162 mm



Ref. **09767** / 1,2 L



Ref. **09768** / 2,2 L



Ref. **09769** / 3,3 L

GN 1/3
 325x176 mm



Ref. **09770** / 1,65 L



Ref. **09771** / 3 L



Ref. **09772** / 4,7 L



Ref. **09786** / 6 L

GN 1/2
 325x265 mm



Ref. **09773** / 2,8 L



Ref. **09774** / 4,85 L



Ref. **09775** / 7,9 L



Ref. **09776** / 10,25 L

GN 1/1
 530x325 mm



Ref. **09777** / 6,25 L



Ref. **09778** / 10,9 L



Ref. **09779** / 17,5 L



Ref. **09780** / 24 L



GN 1/2
 Ref. **09824**



GN 1/1
 Ref. **09829**

Tapas de Apoyo PC

Rotulador HORECA Pág. 57



Rejillas GastroNorm Pág. 51



Tapas Herméticas Pág. 52-53



Tapas de apoyo Pág. 54-55





Cubetas de Policarbonato



La extensa gama de cubetas de Policarbonato ARAVEN. Cuenta con una amplia de medidas GastroNorm y gran variedad de capacidades para ajustar el tamaño del recipiente a la cantidad habitual de consumo

Su transparencia (efecto cristal) permite la rápida identificación del alimento en la cámara de conservación.

No se tiñe. El material policarbonato tiene un efecto barrera que evita que el tinte o colorantes del alimento presente en algunos alimentos o condimentos (tomate, mostaza, cúrcuma, curry...) penetre y tiña las paredes del contenedor.

Su óptimo comportamiento a muy bajas temperaturas permite someter la pieza a procesos de congelación. Soporta también altas temperaturas lo que posibilita su ubicación en mesas expositoras de buffet, baño maría...



¿Qué sistema de tapado debo elegir?



Tapa hermética

Para la conservación alimentos ricos en proteínas (carnes y pescados). La hermeticidad que proporciona el contenedor impide que el aire entre en el interior del recipiente reduciendo la oxidación del alimento.



Tapa de apoyo

Para la conservación de vegetales cerrar el contenedor con una tapa de apoyo no hermética para evitar la condensación de agua en las paredes del recipiente.



Tapa de apoyo con muesca

Protege de la exposición ambiental y evita el riesgo de una contaminación externa en una zona de exposición del alimento (vitrinas, buffet, mesa caliente de servicio...)

Cubetas de Policarbonato

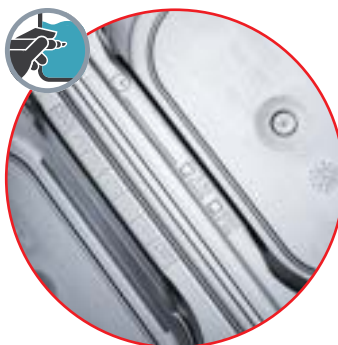

Con el **grabado superficial** en pieza y usando el rotulador ARAVEN Horeca Marker para escribir sobre esta parte de la cubeta, podemos identificar el contenido preservando la información asociada a su origen o su manipulación.

La cubetas van provistas en su borde superior de unos grabados con los días de la semana y hora, para que ubicadas en una mesa de manipulación el operario pueda conocer la hora y día de caducidad del alimento marcadas durante su elaboración.

Hermético: Tapa de bi-inyección material con junta de caucho para asegurar la máxima protección de los alimentos incluso en cubetas grandes.



Escala de contenido: Regleta de medición e indicador de medida GastroNorm.

Medidas GastroNorm: Productos diseñados y fabricados según dimensiones y especificaciones establecidos en la Norma EN 631.1. Selecciona la medida GastroNorm del contenedor ARAVEN que más se adecúe al volumen de materia prima a conservar. Contra más alimento contenga el recipiente menor oxígeno tendrás en el interior del mismo.

Apilables con tapa y encajables en vacío.

Fácil limpieza: Cantos redondeados. Su especial diseño evita que se acumulen restos y facilita la limpieza.



_4010 _4011 _4012 _4015 _4016 _4017 _4019 _4020 _4021 _4025 _4026
 _4027 _4034 _4035 _4036 _4037 _4051 _4052 _4058 _4059 _4060 _4061

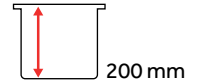
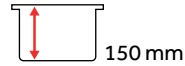
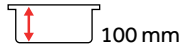
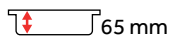
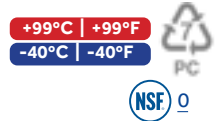

GN 1/9
176x108 mm



Ref. **94010** / 0,6 L



Ref. **94011** / 0,9 L



Ref. **94012** / 1,2 L

GN 1/6
176x162 mm



Ref. **94015** / 1 L



Ref. **94016** / 1,6 L



Ref. **94017** / 2,3 L

GN 1/4
265x162 mm



Ref. **94019** / 1,7 L



Ref. **94020** / 2,6 L



Ref. **94021** / 3,8 L

GN 1/3
325x176 mm



Ref. **94025** / 2,4 L



Ref. **94026** / 3,7 L



Ref. **94027** / 5,5 L

GN 1/2
325x265 mm



Ref. **94034** / 4 L



Ref. **94035** / 6,2 L



Ref. **94036** / 8 L



Ref. **94037** / 11,8 L

GN 2/4
530x162 mm



Ref. **94051** / 5,7 L



Ref. **94052** / 10,8 L

GN 1/1
530x325 mm



Ref. **94058** / 8,6 L



Ref. **94059** / 13,4 L



Ref. **94060** / 20 L



Ref. **94061** / 26,2 L

Rotulador
HORECA
Pág. 57



Rejillas
GastroNorm
Pág. 51



Tapas
Herméticas
Pág. 52-53



Tapas
de apoyo
Pág. 54-55





Cubetas caladas de Policarbonato

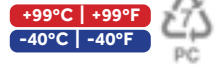

Una correcta conservación de los alimentos que desprenden líquidos conlleva la utilización de cubetas perforadas que permitan la separación del exudado del propio alimento. De esta manera se reduce el nivel de mermas del producto.

Tras el proceso de lavado de vegetales frescos la cubeta perforada permite el rápido escurrido y secado del alimento antes de su conservación o elaboración.

Después de la cocción la cubeta perforada drena el líquido sobrante del vegetal/pasta cocinada.

Una vez troceado el vegetal para emplatado (ejemplo tomate cortado para el montaje de la ensalada en mesa de manipulación) se recomienda conserva en una cubeta perforada para que el líquido que desprende no esté en contacto con el vegetal y ralentice el proceso de putrefacción de los vegetales.



Cubetas caladas de Policarbonato



Óptima geometría: Su diseño ondulado permite que el líquido drene más rápidamente a la cubeta de la base. El espacio por debajo del fondo perforado es suficiente para asegurar que el líquido nunca estará en contacto con el alimento.

Ergonomía: Su borde ergonómico facilita el manejo de la cubeta.

Fácil limpieza: Diseño sin aristas vivas, sin esquinas ni recovecos que puedan acumular este líquido que desprende el alimento.

Medidas GN: Productos diseñados y fabricados según dimensiones y especificaciones establecidos en la Norma EN 631.1.

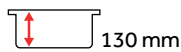

GN 1/6
176x162 mm



Ref. 94073 / 1,9 L



+ Ref. 94017 0,53 L

GN 1/3
325x176 mm



Ref. 94075 / 4,6 L



+ Ref. 94027 1,35 L

GN 1/2
325x265 mm



Ref. 94076 / 7,8 L

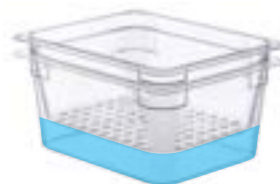

+ Ref. 94036 2,3 L

GN 1/1
530x325 mm



Ref. 94078 / 17,2 L



+ Ref. 94060 5,8 L

Tapas
Herméticas
Pág. 52-53



Tapas
de apoyo
Pág. 54-55



NSF _4073 _4075 _4076 _7048

Rejillas GastroNorm

NSF 00241 00242 00243
00254 00256 01923



Las rejillas GN son elementos esenciales en toda cocina que lleve a cabo procesos de conservación. Su utilización para una correcta conservación de los alimentos que desprenden líquidos reducirá el nivel de mermas por deterioro.

La Rejilla se coloca en el fondo del recipiente y favorece el drenaje de líquido hacia el fondo del mismo evitando así todo contacto entre líquido y alimento, y reduciendo el riesgo para la proliferación bacteriana.

ARAVEN cuenta con rejillas adaptadas a sus contenedores de alimentos (tanto en tamaños GN como en otros tamaños) en cuyo diseño se ha tenido en cuenta la evacuación del exudado, permitiendo así una conservación de calidad.



Óptima geometría: Diseñada para una correcta evacuación del exudado. Altura que permite separar el exudado del alimento, (2 cm). Cumplen con la normativa higiénico-sanitaria que recomienda evitar el contacto entre el alimento y el exudado.

Cantos redondeados: Su especial diseño evita que se acumulen restos y facilita la limpieza.

Ergonomía: Su borde ergonómico facilita el manejo de la rejilla.

GN 1/6 |
120x106 mm | Ref. **00254**

GN 1/4 |
208x100 mm | Ref. **00243**

GN 1/3 |
260x115 mm | Ref. **00242**

GN 1/2 |
260x205 mm | Ref. **00241**

GN 2/3 |
312x283 mm | Ref. **01923**

GN 1/1 |
470x265 mm | Ref. **00256**

Tapas Herméticas



La gama de tapas herméticas ARAVEN de bi-inyección con junta de caucho cierran herméticamente el contenedor y asegura la máxima protección de los alimentos.

Con el tapado hermético se evita que el alimento se reseque y que absorba o libere olores que puedan penalizar su calidad.

El tapado hermético garantiza que el contenido líquido no derrame fuera del contenedor en su conservación y transporte



GN 1/9
176x108 mm



Ref. **04014**

GN 1/6
176x162 mm



Ref. **09852**

GN 1/4
265x162 mm



Ref. **09853**

GN 1/3
325x176 mm



Ref. **09854**

GN 1/2
325x265 mm



Ref. **09855**

GN 1/1
530x325 mm



Ref. **09856**

NSF 04014 09852 09853
09854 09855 09856

Tapas de Silicona GastroNorm

+200°C | +392°F
-40°C | -40°F



Las tapas de silicona ARAVEN cierran con total hermeticidad y ayudan a conservar los alimentos frescos por más tiempo

Menor carga microbiana, menor oxidación y conservando textura, aroma y sabor del alimento.

Gracias a la flexibilidad del material estas tapas son universales y sirven para todo tipo de cubeta de la misma dimensión GastroNorm independientemente del material en el que estén fabricadas. Su transparencia permite la identificación del alimento conservado.

Se puede utilizar en un horno hasta 200 grados y también permite el uso en un microondas, reduciendo el tiempo de cocción y consiguiendo un ahorro energético. En congelación hasta -40 grados.



GN 1/9
176x108 mm



Ref. **91811**

GN 1/6
176x162 mm



Ref. **91812**

GN 1/4
265x162 mm



Ref. **91813**

GN 1/3
325x176 mm



Ref. **91814**

GN 1/2
325x265 mm



Ref. **91815**

GN 2/3
336x309 mm



Ref. **91816**

GN 1/1
530x325 mm



Ref. **91817**

Tapas de apoyo Universal



La tapa de apoyo univesal de ARAVEN permite tapar la mayor parte de las Cubetas GastroNorm en diferentes materiales.

Provista de un asa para facilitar su apertura. Para la conservación de alimentos vegetales crudos con alto contenido en agua los recipientes no deberán de estar cerrados herméticamente, utilizar la tapa de apoyo. Las frutas y las verduras frescas tienen un alto contenido en agua, esta característica resulta crucial para su correcta conservación debido a que, con el paso del tiempo, se produce una pérdida de humedad que puede condensar en las paredes y en el fondo de contenedor de alimentos favoreciendo la aparición de moho y acelerando el proceso de putrefacción de los vegetales.



GN 1/9
176x108 mm



Ref. **94013**

GN 1/6
176x162 mm



Ref. **94018**

GN 1/4
265x162 mm



Ref. **94022**

GN 1/3
325x176 mm



Ref. **94029**

GN 1/2
325x265 mm



Ref. **94038**

GN 2/4
530x162 mm



Ref. **94054**

GN 1/1
530x325 mm



Ref. **94062**

NSF 94013 94018 94022
94029 94038 94062

Tapas de apoyo Universal con muesca

+99°C | +99°F
-40°C | -40°F



La tapa de apoyo universal de ARAVEN permite tapar la mayor parte de las Cubetas GastroNorm en diferentes materiales.

Tiene una muesca para alojar la cuchara o utensilio en la zona de servicio con la tapa posicionada en la cubeta.

En la zona de buffet esta tapa protege el alimento de contaminaciones externas en la exposición hasta el momento del servicio. La tapa va provista de un asa para facilitar su apertura.



GN 1/9
176x108 mm



Ref. **84013**

GN 1/6
176x162 mm



Ref. **84018**

GN 1/4
265x162 mm



Ref. **84022**

GN 1/3
325x176 mm



Ref. **84029**

GN 1/2
325x265 mm



Ref. **84038**

GN 2/4
530x162 mm



Ref. **84054**

GN 1/1
530x325 mm



Ref. **84062**



Sistema de identificación



Ahorro: No requiere de la incómoda y costosa reposición de la etiqueta. No se necesita pegar y despegar etiquetas de papel.

Facilidad de uso y comodidad: Etiqueta con toda la información exigida por Sanidad, es tan sencillo como escribir sobre ella con el rotulador o el portaminas blanco ARAVEN la información detallada en la etiqueta.

Higiene: Etiqueta integrada no deja restos y queda como nueva lavado tras lavado en el lavavajillas.



Rotulador HORECA:

Diseñado especialmente por ARAVEN para ayudar al hostelero a cumplir con la normativa de trazabilidad.

Para facilitar el uso del contenedor con la etiqueta, ARAVEN pone a su disposición el rotulador HORECA marker de tinta permanente a base de agua y de fácil limpieza en el lavavajillas. Basta con que escriba en la etiqueta los datos necesarios, una vez llegue el momento de lavar el contenedor, comprobará como su escritura se elimina fácilmente en el lavado o frotando suavemente bajo un chorro de agua caliente.

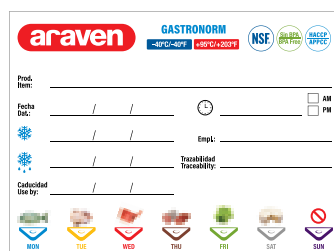

Ref. 00393



Ref. 00394

Portaminas BLANCO:

Portaminas de escritura seca, no permanente, soluble.

Escritura de color blanco: Óptimo para superficies opacas, oscuras y transparentes.

Adecuado para casi todos los materiales: plástico, vidrio, cuero, tela, piedra, metal y madera.

Soluble en agua, no se seca y sin olor.

Recargable con el repuesto de minas Ref. 02395

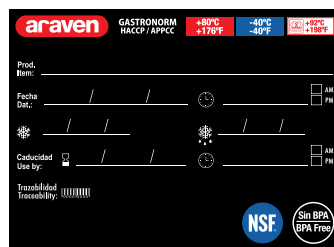

Ref. 02393



Ref. 02395

ColorClip:

7 Colorclips que facilitan la gestión de los alimentos dentro de la cocina en base a distintos criterios.



16x

Ref. 03019

165x100xh6 mm



araven
ALLERGEN-ALLEGENO-ALLERGENE

Free From: No Gluten, No Dairy, No Eggs, No Nuts, No Soy, No Wheat, No Yeast

Contains: No Artificial Flavors, No Artificial Colors, No Parabens, No Phthalates, No Sulfates, No Sulfites, No Talc, No Titanium Dioxide, No Zinc Oxide

Net Weight: 100g

araven
ALLERGEN-ALLEGENO-ALLERGENE

Free From: No Gluten, No Dairy, No Eggs, No Nuts, No Soy, No Wheat, No Yeast

Contains: No Artificial Flavors, No Artificial Colors, No Parabens, No Phthalates, No Sulfates, No Sulfites, No Talc, No Titanium Dioxide, No Zinc Oxide

Net Weight: 100g

araven
ALLERGEN-ALLEGENO-ALLERGENE

Free From: No Gluten, No Dairy, No Eggs, No Nuts, No Soy, No Wheat, No Yeast

Contains: No Artificial Flavors, No Artificial Colors, No Parabens, No Phthalates, No Sulfates, No Sulfites, No Talc, No Titanium Dioxide, No Zinc Oxide

Net Weight: 100g

araven
ALLERGEN-ALLEGENO-ALLERGENE

Free From: No Gluten, No Dairy, No Eggs, No Nuts, No Soy, No Wheat, No Yeast

Contains: No Artificial Flavors, No Artificial Colors, No Parabens, No Phthalates, No Sulfates, No Sulfites, No Talc, No Titanium Dioxide, No Zinc Oxide

Net Weight: 100g

araven
ALLERGEN-ALLEGENO-ALLERGENE

Free From: No Gluten, No Dairy, No Eggs, No Nuts, No Soy, No Wheat, No Yeast

Contains: No Artificial Flavors, No Artificial Colors, No Parabens, No Phthalates, No Sulfates, No Sulfites, No Talc, No Titanium Dioxide, No Zinc Oxide

Net Weight: 100g

araven
ALLERGEN-ALLEGENO-ALLERGENE

Free From: No Gluten, No Dairy, No Eggs, No Nuts, No Soy, No Wheat, No Yeast

Contains: No Artificial Flavors, No Artificial Colors, No Parabens, No Phthalates, No Sulfates, No Sulfites, No Talc, No Titanium Dioxide, No Zinc Oxide

Net Weight: 100g

Herméticos Antialérgenos



Identifica y separa los menús preparados especialmente para los clientes con alergias o intolerancias.

El color morado del hermético ARAVEN identifica y diferencia el alimento de un cliente que padece alergia o intolerancias alimentarias para independizarlo del resto de contenedores y protegerlo de posibles contaminaciones de sustancias potencialmente alérgicas para él.

Al ser identificado correctamente ayudamos a no ser ingerido inadvertidamente por este grupo de riesgo. Con la etiqueta permanente especial identificamos el alérgeno en el Hermético ARAVEN, conservando con todas las garantías los alimentos para los clientes que padecen alergias o intolerancias alimentarias.

Además la hermeticidad completa de los herméticos, está especialmente diseñada para conservar con la máxima garantía y proteger los alimentos de riesgo de contagio por contaminación cruzada por alérgenos alimentarios.



Objetivo

De acuerdo con la nueva Ley de Información Alimentaria (Alérgenos), recogida en el Reglamento Europeo 1169/2011 sobre la información alimentaria facilitada al consumidor, es obligatorio informar sobre los posibles alérgenos presentes en los platos o productos, para que cualquier comensal sepa que puede comer o no sin tener que identificarse como alérgico o intolerante sin pedir un trato especial.

¿Cuándo entró en vigor?

Desde el 13 de diciembre de 2014 todas las empresas alimentarias tienen la obligación de facilitar la información sobre ingredientes alérgicos empleados en los alimentos vendidos o suministrados. Con esta nueva Ley la responsabilidad de que el consumidor tenga una reacción alérgica o intolerancia recae sobre el restaurante y puede enfrentarse a multas y sanciones.

¿A qué establecimientos hosteleros afecta esta Ley?

- Sirven comidas como bares, restaurantes o servicios de catering.
- Venden alimentos sin envasar o envasados a petición del consumidor (fiambres, panes, comidas preparadas o alimentos a granel).
- Venden o suministran alimentos sin envasar a otros establecimientos como escuelas, hospitales, residencias...

¿Cómo facilitar la información?

La información sobre alérgenos debe estar clara, legible y disponible de forma oral o de forma escrita en soportes como el menú, la carta, en una pizarra o en un cartel próximo al alimento.

¿Cuáles son los productos alimentarios que causan alergias o intolerancias sobre los que se debe informar al consumidor?



Lácteos y sus derivados (incluida la lactosa)



Crustáceos y productos a base de...



Sésamo y productos a base de...



Apio y productos derivados



Huevo y productos a base de...



Soja y productos a base de...



Moluscos y productos a base de...



Altramuces y productos a base de...



Pescado y productos a base de...



Gluten y productos derivados...



Azufre Sulfitos Concentraciones (concentraciones > 10mg/kg)



Cacahuets y productos a base de...



Mostaza y productos derivados...



Frutos con cáscara (almendras, avellanas, nueces, pistachos, y productos derivados)

Herméticos Antialérgenos

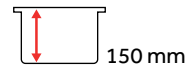

Hermético: doble labio hermético para conservar con todas las garantías los alimentos para los clientes que padecen alergias o intolerancias alimentarias

Etiqueta integrada: la etiqueta permanente especial identifica el alérgeno en el Hermético ARAVEN, conservando con todas las garantías los alimentos para los clientes que padecen alergias o intolerancias alimentarias.

Medidas GastroNorm: Productos diseñados y fabricados según dimensiones y especificaciones establecidos en la Norma EN 631.1.

GN 1/6
176x162 mm



Ref. **61390** / 2,6 L

GN 1/4
265x162 mm



Ref. **61392** / 4,3 L

GN 1/3
325x176 mm



Ref. **61393** / 6 L

GN 1/2
325x265 mm



Ref. **61391** / 10 L

GN 1/1
530x325 mm



Ref. **61397** / 20,5 L

NSF 61390 61391 61397
61392 61393

Rotulador
HORECA
Pág. 57



Cubeta con tapa, tablas de corte y kit antialérgenos

+90°C | +194°F
-40°C | -40°F



Cubetas de gran capacidad de 30 litros con tapa en polipropileno para el transporte alimentario y utensilios anti-alérgenos.

El color morado permite la rápida identificación de las herramientas por parte de los empleados.

Permite conservar con todas las garantías las materias primas catalogadas como potencialmente alérgenas y evitar de esta manera las contaminaciones cruzadas. Permite almacenar con seguridad todos los utensilios utilizados exclusivamente para la manipulación de alimentos potencialmente alérgenos.

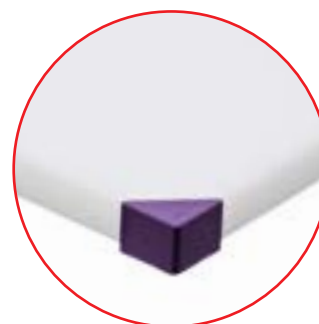

Dosificador con marcas para adecuar el diámetro de salida de caudal y poder introducir todo tipo de aderezos.

Asideros laterales, con cierre para facilitar su manejo y transporte. Apilables con tapa y encajables en vacío.

Aposos antideslizantes, seguridad en el trabajo. La tabla no desliza proporcionando máxima seguridad para el corte.



Ref. **61376** / 35 cl
ø60xh230 mm



Tapón



Ref. **61172** / 30 L
530x396xh159 mm



Kit Antialérgenos +
Ref. **68001**

Ref. **61172**
Ref. **61376**
Ref. **60102**

Ref. **60103**
304x204xh19 mm



Ref. **60102**
404x304xh24 mm



Ref. **60101**
504x304xh34 mm



Ref. **60858**
604x404xh24 mm



Ref. **60859**
604x404xh34 mm





araven

araven		SISTEMA	
Modelo	Capacidad	Color	Material
AR-100	100 L	Blanco	PP
AR-200	200 L	Blanco	PP
AR-300	300 L	Blanco	PP
AR-400	400 L	Blanco	PP
AR-500	500 L	Blanco	PP
AR-600	600 L	Blanco	PP
AR-700	700 L	Blanco	PP
AR-800	800 L	Blanco	PP
AR-900	900 L	Blanco	PP
AR-1000	1000 L	Blanco	PP

Contenedores GastroNorm 2/1

+80°C | +176°F
-40°C | -40°F



+90°C | +194°F
-40°C | -40°F



Las cubetas GN 2/1 permiten el almacenamiento y la conservación de grandes volúmenes de alimentos. Además, las versiones de fondo perforado son óptimas para procesos de descongelación.

Doble posición de la cubeta:

1. Encajable

2. Apilable sin tapa

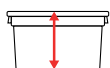

300 mm



17 L



49 L



380 mm



17 L



68 L

Contenedores GastroNorm 2/1



ColorClip. El sistema de identificación de color se posiciona en la base y permite reducir el riesgo de contaminación cruzada e identificar la tipología de alimento que se almacena en el contenedor.

Sistemas de identificación del alimento integrados en las piezas: **Etiqueta permanente** permite identificar el contenido y preservar la información asociada a su origen o su manipulación.

Asa ergonómica y resistente. Regleta de medición.

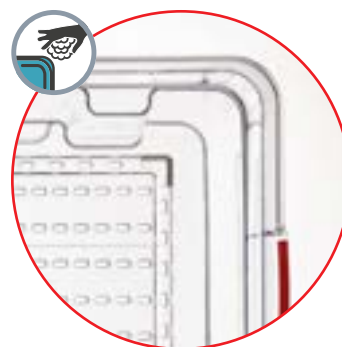

Doble posición de la cubeta: Posición encajable y posición apilable sin tapa.

Óptima geometría. Base ondulada.

Fácil limpieza: Diseño sin aristas vivas, sin esquinas ni recovecos que puedan acumular este líquido que desprende el alimento.

Medidas GastroNorm: Productos diseñados y fabricados según dimensiones y especificaciones establecidos en la Norma EN 631.1. Selecciona la medida GastroNorm del contenedor ARAVEN que más se adecúe al volumen de materia prima a conservar. Contra más alimento contenga el recipiente menor oxígeno tendrás en el interior del mismo.

Carga recomendada

MAX 280kg Cubetas: h300 mm
70kg x 4u.

MAX 360kg Cubetas: h380 mm
90kg x 4u.

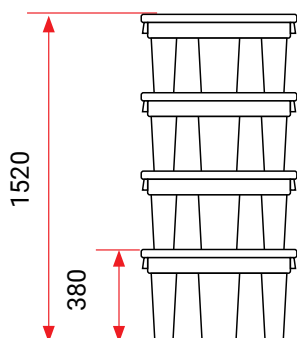
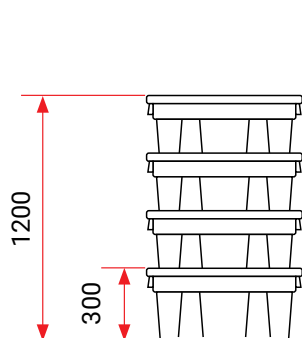



_4069 _4070 _4071 _4079 _4080

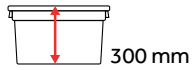

300 mm

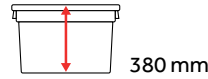

380 mm

Tapa de contacto

GN 2/1
650x530 mm



Ref. 74069 / 70 L



Ref. 74070 / 90 L



Ref. 74071



Ref. 74079 / 70 L



Ref. 74080 / 90 L

Cubetas perforadas

GN 2/1
650x530 mm



Ref. 04069 / 70 L



Ref. 04070 / 90 L



Ref. 04071



Ref. 04079 / 70 L



Ref. 04080 / 90 L

Cubetas perforadas

Rotulador
HORECA
Pág. 57



Kit GN2/1 de
descongelación
Pág. 67



araven





Cubeta perforada. La base ondulada está especialmente diseñada para que exista la menor zona de contacto con el alimento.

La perforación de la base facilita el drenaje del líquido que desaloja el alimento (exudado) en procesos de descongelación. El proceso de descongelación se realiza más rápidamente ya que el líquido que desprenden los alimentos, en carnes y pescados especialmente, drena por los orificios sin acumularse en la zona de contacto.

Los alimentos se colocarán en el interior de la cubeta perforada, encajada sobre la otra cubeta, que recogerá el líquido que desprenda el alimento evitando que gotee y contamine otros alimentos cercanos en la descongelación (exudado o glaseado/líquido de cobertura). Se deberá de proteger el alimento con una tapa para evitar contaminaciones.



Ref. **01828** / 17,5 L
530x325xh200 mm



4,4 L



Ref. **01260** / 35 L
530x396xh285 mm



6,8 L



Ref. **01829** / 70 L
650x530xh318 mm



17 L



49 L

Simaldi



araven
FOOD SAFETY EQUIPMENT



Cubeta 60x40



Cubeta para la fermentación de masas de pizza, también utilizada en el transporte y conservación de las elaboraciones.

Apilado en torre



Apilado con aireación



Apilado en cruz



Cantos redondeados de **fácil limpieza**, sin aristas vivas ni recovecos que puedan alojar restos de suciedad.

Cuenta con una zona de agarre perimetral que **facilita el manejo y transporte** de la cubeta.



4 identificadores de color para la gestión de las masas o el alimento.

Los espesores de pieza y los refuerzos laterales proporcionan robustez y **garantiza su durabilidad**.



Ref. **06041** / 18L
600x400x100 mm



Ref. **06040**
600x400x24 mm

Carro 60x40

INOX



1x Ref. 61226
620x460xh1840 mm



1x Ref. 61227
695x485xh1660 mm

Plataforma extensible

INOX



MAX
200kg

1x

Ref. 47670

620x460mm/487x314 mm



Contenedores Accesibles



Los contenedores accesibles ayudan a optimizar el espacio mediante el uso de métodos eficientes de almacenaje de los alimentos, ayudando a reducir los desperdicios y a mejorar la rotación de las existencias.

Los Contenedores Accesibles son los recipientes más idóneos para la Conservación de alimentos con muy escasa humedad (legumbres, frutos secos, pastas, arroz,...) ya que pueden cerrarse de modo que se proteja el interior sin ser necesaria la hermeticidad, consiguiendo evitar que la humedad entre en ello y los deteriore. Después bastará con elegir bien el lugar donde se va a ubicar el contenedor, para ello deberemos colocarlos en lugares secos y bien ventilados, lejanos a focos de calor y de humedad y aislados del ambiente si éste resulta muy húmedo.



SISTEMA FIFO/PEPS

Mayor control de existencias.

El Contenedor Accesible GastroNorm 1/1 está diseñado con el sistema FIFO/PEPS (lo primero que entra es lo primero que sale) con tapa de carga y de descarga. Recomendación APPCC/HACCP.

Carga y descarga independientes en GN1/1 para facilitar el control del contenido y una ordenada rotación de los alimentos.



Contenedores Accesibles



Fácil accesibilidad: Se puede acceder al contenido de cualquiera de los contenedores apilados sin necesidad de desapilar, ventaja importantísima por la rapidez y mantenimiento del orden. La tapa se queda elevada en posición de apertura sin necesidad de sujetarla permite su total apertura incluso con otro contenedor apilado y ubicada en la estantería. Altura que se adapta a la separación entre baldas.

Etiqueta integrada: La etiqueta Permanente permite al profesional de la cocina identificar el contenido y preservar la información asociada a su origen ayudando a cumplir con la Normativa de Trazabilidad Reg (CE) 852/2004 y Reg (CE) 178/2002 referentes a los alimentos.

Translúcido: La ventana frontal, la etiqueta integrada y la transparencia de la pieza permiten una rápida identificación del alimento.

Fácil limpieza: Cantos redondeados. Su especial diseño evita que se acumulen restos y facilita la limpieza.

Ergonomía: Asas laterales para un fácil manejo y transporte.

ColorClip: Código de color para evitar la contaminación cruzadas entre alimentos.

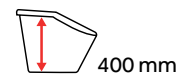

Ref. **09308** / 14 L
480x230x227 mm



GN 1/3
395x200 mm



Ref. **09146** / 7 L

GN 2/3
415x340 mm



Ref. **09145** / 16 L



Ref. **09457** / 18 cl
250x80x55 mm



Ref. **09265** / 60 cl
126x110x120 mm

GN 1/1
565x340 mm



SISTEMA FIFO
Ref. **09144** / 22,65 L



SISTEMA FIFO
Ref. **00918** / 50 L

Contenedores Accesibles



Los Contenedores Accesibles están diseñados para un perfecto almacenaje, una optima conservación con la máxima higiene y el más riguroso control de las materias primas.

Incrementa la eficiencia de los procesos de manipulación y conservación. Contenedores de gran capacidad especialmente diseñados para la conservación de alimentos secos, no perecederos o a granel, sin necesidad de refrigeración y en unas condiciones de temperatura y humedad adecuadas.

Facilitan el correcto traspaso de los alimentos y su etiquetado para una correcta conservación reduciendo el nivel de mermas.

Cuando los productos secos (legumbres, pasta, arroz, etc.) se sirven a granel o en grandes sacos y se traspasan a contenedores accesibles del establecimiento, hay que identificarlos con la información de la etiqueta original (marca del producto, número de lote, fecha de apertura y fecha de caducidad o de consumo preferente) en el nuevo contenedor, asegurando la trazabilidad de la materia prima.



Ruedas resistentes en poliamida en los tamaños de 80 L y 100 L para facilitar el transporte.



Etiqueta permanente de trazabilidad: Podemos registrar la procedencia del alimento, su elaboración, la fecha de conservación...



Ref. **00919** / 80 L
655x435x560 mm



Ref. **00920** / 100 L
705x465x580 mm



Ref. **09459** / 95 cl
280x120x120 mm



Ref. **09469** / 190 cl
330x150x140 mm



Contenedores cuadrados



Su geometría cuadrada optimiza el espacio en el almacenamiento, sin desperdiciar huecos.

Para el almacenamiento de alimentos no perecederos con escasa humedad como legumbres, pastas arroz, etc., se recomienda utilizar contenedores con tapa que puedan cerrarse, sin ser necesaria la hermeticidad, consiguiendo evitar que la humedad entre en ellos y los deteriore. Para la conservación líquidos y almacenamiento de secos.

Asideros laterales en el exterior que facilitan su manejo y transporte.

Permite el apilamiento con tapa y en vacío pueden encajarse uno dentro de otro reduciendo el espacio, con una fácil extracción gracias a sus líneas de apoyo.

Idóneos para la conservación a granel de alimentos con escasa humedad (legumbres, pasta, frutos secos, arroz...) Su hermeticidad permite la adecuada conservación y transporte de salsas, cremas y otros líquidos.



Contenedores cuadrados



ColorClip: Código de color para evitar las contaminaciones cruzadas. Los Contenedores ARAVEN, gracias a su identificación ColorClip, ayudan a prevenir la Contaminación Cruzada, asegurando que el contenido de este recipiente va a ser siempre de la misma naturaleza.

Asidores laterales: Para facilitar su manejo y el transporte.

Regleta de medición para un perfecto control de las existencias.



Texturizado: en esquinas y base protegen a la pieza de roces y golpes.

Cantos redondeados: Su especial diseño evita que se acumulen restos y facilita la limpieza. Las esquinas redondeadas facilitan el vertido de líquidos

Apilables con tapa encajables en vacío.



Hermético: Doble Cierre hermético para una total protección del alimento. Para un correcto cierre se debe presionar en los cuatro lados de la tapa hasta escuchar un "clic".

La tapa está fabricada en LDPE material más flexible que permite un correcto ajuste a la base.

Fácil apertura: El contenedor va provisto de un tirador en la tapa que facilita su apertura.

Sistemas de identificación del alimento integrados en las piezas: **Etiqueta permanente** permite identificar el contenido y preservar la información asociada a su origen o su manipulación.



_1851_1852_1853_1854_1855_1856_1857

+99°C | +99°F
-40°C | -40°F



NSF 3



195 mm

Ref. **31851**
h100 mm / 2 L



Ref. **31852**
h190 mm / 4 L



235 mm

Ref. **31853**
h190 mm / 6 L



Ref. **31854**
h230 mm / 8 L



290 mm

Ref. **31855**
h210 mm / 12 L



Ref. **31856**
h320 mm / 18 L



Ref. **31857**
h400 mm / 22 L



11851 11852 11853 11854 11855 11856 11857

+95°C | +203°F
-40°C | -40°F

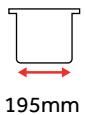

195mm

Ref. **11851**
h100 mm / 2 L



Ref. **11852**
h190 mm / 4 L



235mm

Ref. **11853**
h190 mm / 6 L



Ref. **11854**
h230 mm / 8 L

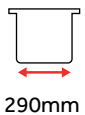

290mm

Ref. **11855**
h210 mm / 12 L



Ref. **11856**
h320 mm / 18 L



Ref. **11857**
h400 mm / 22 L



Otras cubetas



El Contenedor Portahuevos GN permite conservar tapado con todas la garantías y una correcta visibilidad del interior.



Ref. **70378** · GN 2/3 | + 4 bandejas
354x325xh200 mm | 30 huevos por bandeja

Ref. **73056** · GN 2/3
290x290xh40 mm

La sustitución de los embalajes originales de los proveedores evita la introducción en la cámara de nuevas contaminaciones.

En el caso de los huevos, esta práctica es especialmente importante ya que tradicionalmente los huevos han sido foco de transmisión de la Salmonella (tanto el propio huevo como los cartones), por ello es adecuado el cambio de envase.

Materiales porosos como la madera o el cartón no están autorizados por la normativa en las cámaras frigoríficas, por tratarse de métodos totalmente antihigiénicos deben ser sustituidos por otros materiales como el plástico. También es recomendable disponer de cámaras diferentes por tipos de alimentos e introducir estos huevos en la cámara de verduras.

Cubeta cuadrada y redonda



Ref. **00446** / 30 L
ø 385xh385 mm



Ref. **00448** / 60 L
415x415xh500 mm



Cubetas con tapa GastroNorm

+95°C | +203°F
-40°C | -40°F



La Cubetas con tapa GastroNorm permiten múltiples posibilidades de cierre y apilamiento.

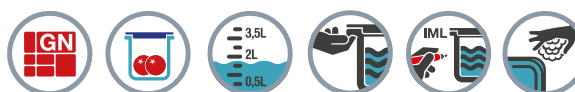

Las cubetas dan la posibilidad de encajar cubeta con cubeta y conseguir así mayor capacidad si se necesita. La tapa tiene dos posiciones de cierre: uno por clipado y otro por apoyo que aporta una mayor seguridad en el apilamiento. La tapa de medidas GN tiene también un doble uso al poderse utilizar como bandeja.

Etiqueta integrada: La etiqueta Permanente permite al profesional de la cocina identificar el contenido y preservar la información asociada a su origen ayudando a cumplir con la Normativa de Trazabilidad Reg (CE) 852/2004 y Reg (CE) 178/2002 referentes a los alimentos.

Translúcido: Permite identificación del alimento contenido. **Ergonomía:** Su borde ergonómico facilita el manejo de la cubeta. **Cantos redondeados:** Su especial diseño evita que se acumulen restos y facilita la limpieza. **Medidas GastroNorm:** Productos diseñados y fabricados según dimensiones y especificaciones establecidos en la Norma EN 631.1.

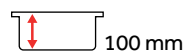
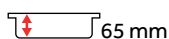

GN 1/2
325x265 mm

Ref. **09297** / 6 L

Rotulador
HORECA
Pág. 57



GN 1/1
530x325 mm

Ref. **09292** / 9 L

Ref. **09293** / 13 L

Rejillas
GastroNorm
Pág. 51



Cubeta 4 compartimentos con tapa

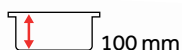

+95°C | +203°F
-40°C | -40°F



GN 1/1
530x325 mm

Ref. **99863** / 2 L x 4 compartimentos





Carro GastroNorm 1/1

INOX



	GN 1/3	GN 1/2	GN 1/1
	h65 mm x 54 u.	h65 mm x 36 u.	h65 mm x 18 u.
	h100 mm x 24 u.	h100 mm x 16 u.	h100 mm x 8 u.
	h150 mm x 24 u.	h150 mm x 16 u.	h150 mm x 8 u.
	h200 mm x 18 u.	h200 mm x 12 u.	h200 mm x 6 u.

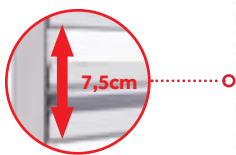

MAX
112kg

1x
Ref. **61222**
550x380xh1745 mm

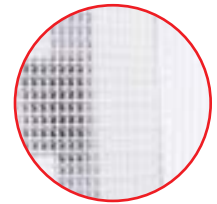

PVC

1x
Ref. **61228**
600x400xh1565mm



Torres de cubetas GastroNorm



Máxima higiene: su diseño permite una rápida bajada de la temperatura del alimento al permitir la circulación del aire frío por el exterior de la cubeta.

Las torres de cubetas Gastroven, al contrario de lo que ocurre en los contenedores apilados, permiten la circulación del aire por el exterior de la cubetas. De esta forma los alimentos se enfrían más rápido y se conservan en mejores condiciones, disminuyendo el riesgo de proliferación bacteriana y reduciendo el consumo de energía.



La Torre de cubetas ARAVEN asegura una óptima conservación de alimentos con humedad (frutas y verduras).

Las frutas y las verduras frescas tienen un alto contenido en agua. Esta característica resultará crucial para su correcta conservación ya que con el paso del tiempo se desprenden de este agua que, en forma de humedad, puede condensar en las paredes y el fondo del contenedor de alimentos produciéndose un proceso de putrefacción en ellos.

Con objeto de evitar este deterioro, los recipientes destinados a guardar este tipo de alimentos no podrán estar cerrados herméticamente y deberán estar provistos de zonas de ventilación que permitan eliminar el agua evaporada sin que se dé la condensación.

La propia estructura de la torre hace las veces de tapa del contenedor, por lo que la cubeta no necesita una tapa adicional, dotando de esta manera a la torre de unas zonas de ventilación para conseguir que las corrientes de aire enfríen los alimentos rápidamente, conservándose a adecuadas temperaturas de refrigeración y evitando que se acumule humedad en su interior impidiendo la proliferación de mohos.

Las torres GastroNorm ARAVEN permiten conservar los contenedores con tapa optimizando el espacio en la zona de almacenamiento.

Máximo aprovechamiento del espacio al permitir el almacenamiento en vertical, incrementando la capacidad de almacenaje.

Fácil apilamiento y total accesibilidad: Se puede acceder al contenedor con tapa apilado sin necesidad de desapilar los superiores. Puedes extraer el hermético sin tener que mover ningún otro contenedor manteniendo el orden en el espacio de almacenamiento proporcionando Rapidez y Agilidad en los procesos.

Máxima protección del alimento. Pensado para alojar los contenedores GastroNorm con tapa. Válido para toda la gama de herméticos GastroNorm 1/1 y 1/2 altura 100mm. También cubetas con tapa inox.

Carro GastroNorm. Proporcionamos una total hermeticidad al contenedor que se ubica en la torre GastroNorm, asegurando el transporte cuando le acoplamos ruedas.

Torres de cubetas GastroNorm



Mejor accesibilidad al alimento: Las cubetas son Cajones fácilmente extraíbles que permiten acceder fácilmente al contenido. La extracción del cajón favorece el acceso al contenido.

GastroNorm: Aptos para alojamientos GastroNorm. Permite ubicar en su interior cubetas GN 1/1 y GN 1/2 altura 100mm.

Etiqueta integrada: Para el cumplimiento de la normativa de trazabilidad: Reg. (CE) n.852/2004 y Reg. (CE) n.178/2002. No requiere de la incómoda y costosa reposición de la etiqueta. No se necesita pegar y despegar etiquetas de papel.

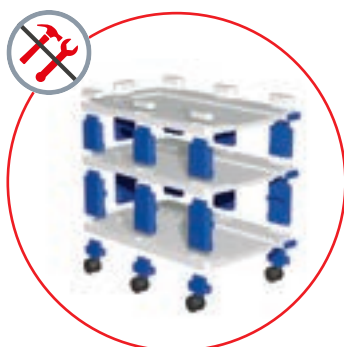

Fácil montaje y desmontaje para limpieza: No se necesitan herramientas y permite el lavado en el lavavajillas.

Pestillos de cierre.

Optimización del espacio en diferentes ubicaciones: La torre se adapta al espacio entre baldas. Acoplándole ruedas se convierte en carro.

Carga recomendada

Las Ruedas para acoplar a la Torre de Cubetas Gastroven sitúan la estructura a una distancia del suelo de unos 10 cm, permitiendo el acceso a la parte inferior para labores de limpieza.

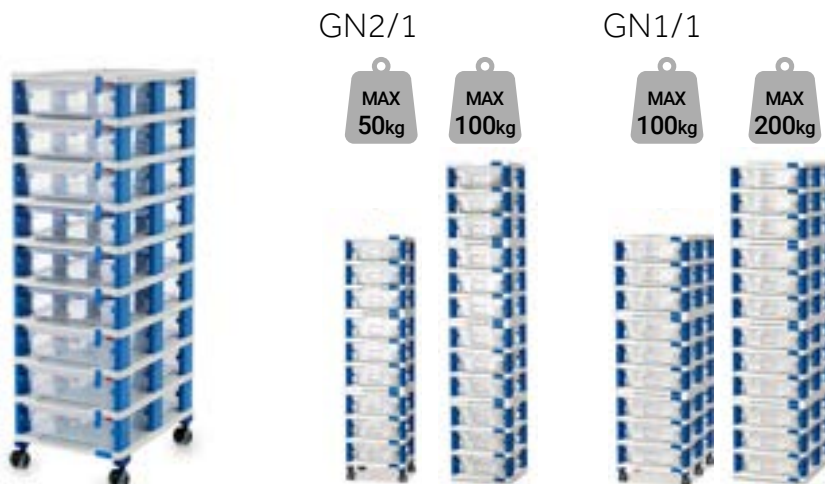

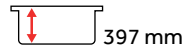

GN 1/2
357x312 mm



Ref. **18862**



Ref. **19862** + 3x
Ref. 03033



Ref. **18237** + 3x
GN 1/2 h100 mm

Cubetas y
herméticos



Ref. **03033**
Pág. 25



Ref. **07822** | **07774**
Pág. 28-29



Ref. **09822** | **09774**
Pág. 36-37



Ref. **94035**
Pág. 41



Ref. **09297**
Pág. 68

GN 1/1
562x372 mm



Ref. **18861**



Ref. **19861** + 3x
Ref. 03036



Ref. **18227** + 3x
GN 1/1 h100 mm

Portacubiertos
HORECA



Ref. **41128**
Pág. 137



Ref. **07827** | **07778**
Pág. 28-29



Ref. **09827** | **09778**
Pág. 36-37



Ref. **94059**
Pág. 41



Ref. **09293**
Pág. 68

Cubetas y
herméticos



Ref. **03036**
Pág. 25

x2 **x2**



Ref. **18240**

Rotulador
HORECA
Pág. 57



Rejillas
GastroNorm
Pág. 51



Set de
4 ruedas



Organizar correctamente la cámara de conservación



Una correcta organización de la cámara de conservación, con una correcta colocación de los alimentos en función de su grupo y naturaleza, cumplirá no sólo con un objetivo de mejorar la productividad en la cocina, sino también de reducir los riesgos higiénico-sanitarios.

Se conoce como contaminación cruzada al proceso por el cual los alimentos entran en contacto con sustancias ajenas, generalmente nocivas para la salud.

Evitar contaminaciones cruzadas. Para ello, es fundamental separar siempre los alimentos cocidos o listos para consumir de los que aún están crudos y siempre que sea posible establecer zonas según tipologías de alimentos en cámaras de refrigeración separadas. Al guardarlos en la misma Cámara de conservación, es mejor establecer zonas que permitan organizar separadamente los alimentos, los contenedores con alimentos crudos en la parte inferior, y evitar así que puedan gotear y contaminar a los ya preparados. Recuerda que es necesario utilizar recipientes herméticos para conservar los alimentos debidamente protegidos e identificados.

A temperatura ambiente se almacenan los productos alimenticios no perecederos, en cubetas con tapa de gran capacidad (por ejemplo legumbres secas, pastas, latas, cereales, etc.) no precisan de condiciones especiales de conservación, lugares ser frescos, secos y bien ventilados.

Las cámaras frigoríficas o de frío positivo deben estar a temperaturas entre 0° y 8°C, en función del tipo de producto. Las temperaturas ideales de refrigeración se encuentran comprendidas entre 0°C y +4°C, pero la temperatura que debe tener una cámara de refrigeración con diversos productos se ajustará a la del que más frío necesite.

Las cámaras de congelación o frío negativo deben estar a temperaturas inferiores a -18°C.

Organizar correctamente la cámara de conservación

Una correcta organización de la cámara de conservación reduce riesgos higiénico-sanitarios, mejora la productividad y ayuda a una gestión eficiente de la cocina y a la implantación del sistema APPCC.



Baldas superiores. Los contenedores con alimentos ya elaborados deberán colocarse debidamente tapados en las baldas superiores de las estanterías. De esta manera, evitamos que encima de un alimento que ya ha pasado por el tratamiento térmico caiga cualquier tipo de resto que pudiera generar la contaminación cruzada. Si, por el contrario, cayeran restos de un alimento ya elaborado encima de un alimento crudo, el tratamiento térmico posterior de ese alimento eliminaría dichas bacterias reduciendo el riesgo de contaminación.

Baldas intermedias. Carnes y pescados crudos se ubicarán sobre los estantes intermedios de las estanterías en las cámaras de conservación.

Baldas inferiores. Las frutas y verduras crudas destinadas a comerse elaboradas con tratamiento térmico posterior (asado, cocción,...) se ubicarán en los estantes inferiores de las estanterías en las cámaras de conservación.

Frutas y verduras destinadas a comerse crudas: lechuga, tomates, zanahorias,... deberán ubicarse en una zona de la cámara que quede separada del resto, procurando no mezclarlas en una misma estantería con otra tipología de alimentos. Si esto no fuera posible, se intentaría ubicarlos debidamente tapados y protegidos en baldas altas.

Medidas que se deben tener en cuenta en las cámaras de conservación



1. El interior de las cámaras debe estar limpio y seco.
2. No se debe sobrecargar la capacidad de las cámaras.
3. Separar adecuadamente los alimentos para facilitar la circulación del aire.
4. Registrar la temperatura de las cámaras de conservación para asegurar su correcto funcionamiento.
5. Identificar los productos con etiquetas en las que se indique nombre del producto, origen, fecha de entrada en cámara, peso, etc.
6. No dejar contenedores de alimentos apoyados directamente en el suelo.

Soporte bajo balda

+70°C | +158°F
-40°C | -40°F



El soporte bajo balda de ARAVEN crea un nuevo alojamiento adicional para el almacenaje y conservación de alimentos.

El soporte puede utilizarse en cualquier punto a lo largo de la estantería y se adapta a cualquier medida Gastronorm. Su sistema guiado permite extraer los recipientes cómodamente de forma horizontal evitando la apilabilidad.

GN 1/9

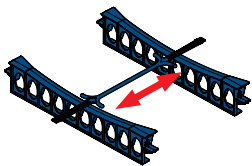

GN 1/1

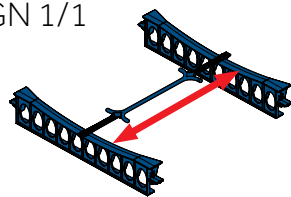

Soporte bajo balda



Ref. **00952**
465x40xh70 mm

Estanterías

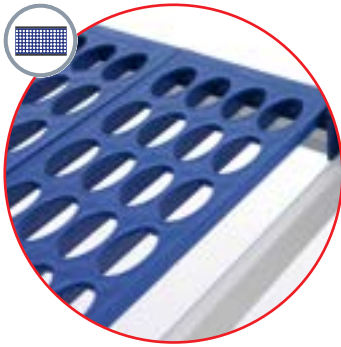

Baldas perforadas para la circulación del aire. Material de las baldas: PP. Baldas completamente desmontables para una cómoda limpieza.

Carga repartida, desde 120Kg hasta 150Kg por altura de estante, según modelo.

Fácil montaje y desmontaje, permite el mantenimiento, la limpieza, la desinfección y la vigilancia. No se necesitan herramientas para montaje.

Permite el lavado de las baldas en el lavavajillas.

Estructura de Aluminio anodizado de gran resistencia mecánica y a la corrosión. Tornillería en acero inoxidable. Estantes regulables en altura cada 150 mm.

Patas regulables y ajustables para una total estabilidad.



Ref. **03406**
97,5x47,5xh170 cm

x4
MAX
150kg

+150°C | +302°F
-25°C | -13°F



+95°C | +203°F
-40°C | -40°F



Estanterías extensibles

Las estanterías extensibles ARAVEN con largueros telescópicos permiten cubrir distintas medidas que van desde los 89cm hasta los 1,8m.

La principal ventaja del producto es la adaptabilidad de la estantería al espacio disponible evitando tener que encargar estanterías a medida optimizando el coste y el espacio lo que supone un ahorro.

El sistema facilita el transporte al ir completamente desmontada en una caja de medidas ajustadas. Fácil de montar y desmontar.

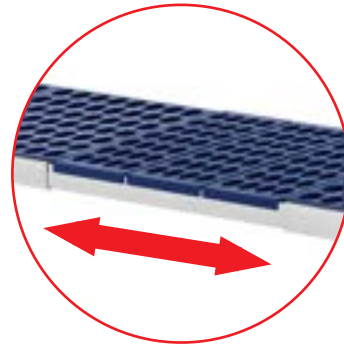

89 cm



100 cm



120 cm



135 cm



Ref. **00950**

89/135x48xh167 cm



139 cm



153 cm



169 cm



184 cm



Ref. **00951**

139/184x48xh167 cm



Estanterías esquineras



00960 + 00950



00960 + 00951



00960 + 03406



Ref. **00960**

89/135x48xh167 cm



00961 + 00950

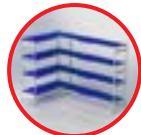

00961 + 00951



00961 + 03406



Ref. **00961**

139/184x48xh167 cm





Manipulación



Todo el equipo y los utensilios empleados en las zonas de manipulación de alimentos y que puedan entrar en contacto con los mismos deberán ser de un material que no transmita sustancias tóxicas, olores ni sabores, que no sea absorbente, resistente a la corrosión y capaz de soportar repetidas operaciones de limpieza y desinfección. Las superficies habrán de ser lisas y estar exentas de hoyos y grietas.

Los productos ARAVEN ayudan a la aplicación de Prácticas Correctas de Higiene por parte de los establecimientos de Hostelería favoreciendo la prevención, reducción o eliminación de un posible riesgo en las diferentes fases de elaboración y manipulación de alimentos.

Se han diseñado con el objetivo de reducir al mínimo el riesgo de contaminación de los productos alimenticios. Además, estos útiles de trabajo destinados a entrar en contacto con alimento están fabricados con materiales resistentes a la corrosión y fáciles de limpiar y desinfectar.

Durante la manipulación de carnes y pescados hay que tener especial cuidado en mantenerlos fuera del rango de temperaturas

de peligro de proliferación bacteriana (8 °C a 65 °C).

Se debe proceder cuanto antes a su cocinado o conservación en frío, evitando trabajar en ambientes con exceso de calor.

Separar siempre los alimentos crudos, de los cocinados y de los que se consumirán en crudo y ya están limpios.

Las zonas de trabajo con alimentos crudos deben estar siempre separadas de las zonas de trabajo con alimentos cocinados y pre-cocinados.

Utilizar utensilios de cocina diferentes (tenedores, cuchillos, platos, tablas de cortar, etc.) para manipular los alimentos crudos. La utilización de tablas de corte diferentes para cada alimento evita la contaminación cruzada.

La esquina de color de la tabla de ARAVEN identifica el tipo de alimento a manipular. La Tabla de Corte ARAVEN tiene unas esquinas de color permanentes, que permiten diferenciar las superficies de trabajo según grupos de alimentos y evitan la contaminación cruzada.



Tablas de corte antideslizantes



Lácteos



Carnes rojas



Pescados



Aves



Vegetales



Elaborados



Alérgenos

La Tabla de Corte ARAVEN es un aliado fundamental en la implantación de sistemas APPCC/HACCP en procesos de manipulación asegurando que las operaciones de troceado, fileteado, despiece,... se llevan a cabo siempre con la misma tipología de producto: carne, pescado, verduras, lácteos, embutidos.

En la práctica las tablas, bien por desgaste u otras causas, no asientan correctamente sobre las superficies de las mesas de trabajo por lo cual los manipuladores colocan en la base trapos u otros elementos que por el exudado de los alimentos terminan siendo un foco de contaminación.

La Tabla de Corte ARAVEN asienta correctamente sobre las superficies de trabajo gracias a sus esquinas permanentes de caucho sobreinyectado. Estos apoyos impiden a la tabla deslizarse sobre estas superficies aportando una mayor seguridad en estos procesos de trabajo.

Las superficies de trabajo que vayan a estar en contacto directo con los alimentos deberán ser sólidas, duraderas

y fáciles de limpiar, mantener y desinfectar. Deberán estar hechas de material liso, no absorbente y no tóxico, e inerte a los alimentos, los detergentes y los desinfectantes utilizados en condiciones de trabajo normales.

Deberá evitarse el uso de madera y otros materiales que no puedan limpiarse y desinfectarse adecuadamente, a menos que se tenga la certeza de que su empleo no será una fuente de contaminación. Las tablas de corte ARAVEN están fabricadas en PE de alta densidad, material plástico con alta resistencia a la corrosión que impide el paso de la humedad. Su superficie es de color blanco que no oculta la suciedad tal y como sucede en la utilización de tabla de colores.

Patentado

Tablas de corte antideslizantes

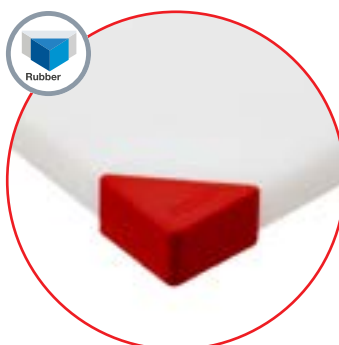
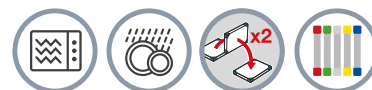

Codificación color: La esquina de color de la tabla identifica el tipo de alimento a manipular. La Tabla de Corte ARAVEN tiene unas esquinas de color permanentes, que permiten diferenciar estas superficies de trabajo según grupos de alimentos a manipular evitando así la contaminación cruzada. En especial, esta diferenciación, tiene mayor importancia entre alimentos crudos y elaborados

Esquinas permanentes integradas por sobre-inyección: Incorpora unas patas de caucho en las esquinas que no se pierden. Las patas de caucho quedan permanentemente unidas al cuerpo de PE.

Apoyos antideslizantes, seguridad en el trabajo: La tabla no desliza proporcionando máxima seguridad para el corte. No necesita trapos para que no deslice, evitando un posible foco de infección.



Reversible: Puede utilizarse por ambos lados. Alarga la vida útil de la tabla de corte.

Higiene: Color limpio que no oculta la suciedad tal y como sucede en la utilización de tabla de colores. Permite el lavado en el lavavajillas.

Orden: Las tablas se pueden guardar verticalmente sin ningún elemento adicional.



○ Ref. 00 --- ● Ref. 02 --- ● Ref. 03 --- ● Ref. 05 --- ● Ref. 07 --- ● Ref. 22 --- ● Ref. 60 ---

19mm

24mm

34mm



Ref. __103
304x204xh19 mm



Ref. __102
404x304xh24 mm



Ref. __101
504x304xh34 mm



Ref. 08103
304x204xh19 mm



Ref. 08102
404x304xh24 mm

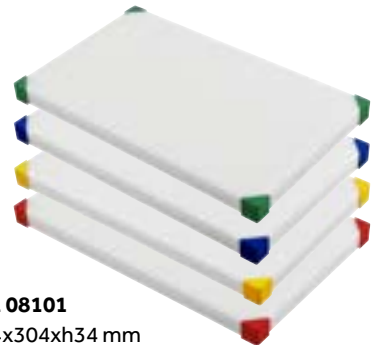

Ref. 08101
504x304xh34 mm



○ Ref. 00 --- ● Ref. 22 --- ● Ref. 03 --- ● Ref. 05 --- ● Ref. 07 --- ● Ref. 32 --- ● Ref. 60 ---

24 mm

34 mm



Ref. __858
604x404xh24 mm



Ref. __859
604x404xh34 mm



Dosificador de salsas



Los Dosificadores de Salsa ARAVEN se usan para introducir todo tipo de aderezos, más ligeros o más espesos, aceites, salsas, reducciones, jarabes... Permiten decorar un plato de forma limpia, alinear con la cantidad justa una ensalada o cualquier otra elaboración y disponer de una amplia variedad de aderezos conservados con toda seguridad.

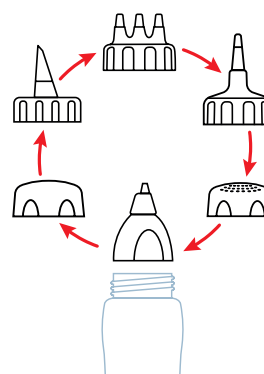

Boquillas intercambiables

Boquillas intercambiables



Antigoteo

Precisión

Tres puntas

Aceitero

Tapón Hermético

Grano grueso

Grano fino

Dosificador de salsas



Escala de medición: Escala de medición en las dos posiciones. **Trazabilidad:** Zona para rotular datos de trazabilidad.

Ergonomía: Zona de agarre ergonómica. Permite controlar el caudal por la presión ejercida. Alinear con la cantidad justa.

Fácil llenado y limpieza. Amplia boca de entrada de bote que facilita el llenado y la limpieza.

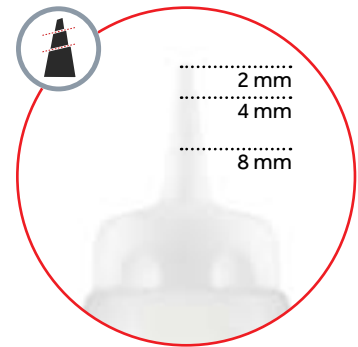

Dosificador antigoteo: Biberón con válvula de silicona antigoteo. El Antigoteo impide que se obture y que se acumulen restos de la salsa en el agujero de salida. Permite conservar en el mismo envase, la válvula tapa el envase.

Dosificador de aceites: El líquido sobrante que escurre por la boquilla vuelve al interior del bote por el orificio de la base. Este orificio también regula el flujo de caída al dispensar.

Dosificador de precisión: La boquilla finaliza en punta lo que permite decorar con precisión y de una forma limpia. Marcas de corte para ajustar el diámetro de la boquilla. Tapón de cierre



Dosificador triple boquilla: La triple boquilla permite repartir la salsa de una manera más homogénea y agiliza el proceso dispensando la salsa más rápidamente. Para el platado facilita la decoración de la elaboración.

Boquilla

+90°C | +194°F
-40°C | -40°F



35 cl
ø70xh193 mm

50 cl
ø70xh233 mm

75 cl
ø75xh273 mm

100 cl
ø80xh312 mm



Antigoteo

Ref. **02554**



Ref. **02555**



Ref. **02556**



Ref. **02557**



Ref. **05554**



Ref. **05555**



Ref. **05556**



Ref. **05557**



Ref. **00554**



Ref. **00555**



Ref. **00556**



Ref. **00557**



Dosificador
de precisión

Ref. **21376**



Ref. **21377**



Ref. **21378**



Ref. **21379**



Ref. **51376**



Ref. **51377**



Ref. **51378**



Ref. **51379**



Ref. **01376**



Ref. **01377**



Ref. **01378**



Ref. **01379**





Mini Dosificadores

+90°C | +194°F
-40°C | -40°F



Boquilla



Reutilizables, fácil llenado y limpieza

Solución para el **tratamiento de salsas concentradas o de un mayor coste con dosis mas reducidas.** Dosifican la cantidad justa y precisa en el emplatado de las elaboraciones. Precisión y rosca fiable con cierre rápido.



9 cl
Ø 48x110 mm

15 cl
Ø 50 x 138 mm

25 cl
Ø 56 x 167 mm



Dosificador de precisión

Ref. **01373**



Ref. **01374**



Ref. **01375**





Araven

3000 ml
2500 ml
2000 ml
1500 ml
1000 ml
500 ml
0 ml

Araven

1000 ml
800 ml
600 ml
400 ml
200 ml
0 ml

Araven

1000 ml
800 ml
600 ml
400 ml
200 ml
0 ml

Purple cap

Red cap

Blue cap

Green cap

Yellow cap

Dosificador de salsas antigoteo



Boquilla



Bote

SI Válvula



En la restauración de comida rápida se demandan soluciones para la búsqueda de la excelencia operativa. Alto nivel de operatividad, eficiencia en la cocina, menús estandarizados y procesos de elaboración centrados en reducir tiempos y costes para conseguir rápidas entregas de los menús con precios competitivos.



Ligero



Regleta de medición



Trazabilidad



Fácil llenado



Fácil limpieza



Ergonomía



6x
Ref. **00957**
Ø65x40 mm



6 (set 6)x
Ref. **00958**
Ø57x18 mm

16x

45 cl

Ref. **00954**
Ø70xh206 mm

16x

70 cl

Ref. **00955**
Ø75xh246 mm

16x

95 cl

Ref. **00956**
Ø75xh286 mm



Dosificador de salsa 3 puntas



Boquilla



Bote



En la restauración de comida rápida se demandan soluciones para la búsqueda de la excelencia operativa. Alto nivel de operatividad, eficiencia en la cocina, menús estandarizados y procesos de elaboración centrados en reducir tiempos y costes para conseguir rápidas entregas de los menús con precios competitivos.



Ligero



Regleta de medición



Trazabilidad



Fácil llenado



Fácil limpieza



Ergonomía



16x

50 cl

Ref. **03377**

Ø60xh235 mm



16x

75 cl

Ref. **03378**

Ø75xh225 mm



6 mm

Dispensador de grano

+90°C | +194°F
-40°C | -40°F



El dispensador de grano ARAVEN está disponible para grano fino, tales como sal, pimienta, azúcar glas o harina mientras que el recipiente para grano grueso es perfecto para especias.

El dispensador de **grano fino** presenta orificios de salida de **2 mm.** de diámetro. El bote **especiero** de **4 mm.** de diámetro.

Escala de medición: Escala de medición en las dos posiciones. **Trazabilidad:** Zona para rotular datos de trazabilidad.

Ergonomía: Zona de agarre ergonómica. Aliñar con la cantidad justa.

Fácil llenado y limpieza. Amplia boca de entrada de bote que facilita el llenado y la limpieza.

350 gr
Ø 60xh162 mm

500 gr
Ø 60 xh212 mm

100 cl
Ø 75xh311 mm



Ø 2 mm



Ref. **01380**



Ref. **01381**



Bote para líquidos



Ref. **00847**



Ø 4 mm



Ref. **71280**



Ref. **71281**

Dispensador de aceite



16x



35 cl

Ref. **71276**

Ø60xh203 mm



16x



50 cl

Ref. **71277**

Ø60xh261 mm



16x



75 cl

Ref. **71278**

Ø75xh251 mm



16x



100 cl

Ref. **71279**

Ø75xh311mm

Organizadores de dosificadores



El organizador de dosificadores de salsas o biberones ayuda a conservar correctamente las salsas mientras se manipulan. Mantienen el orden en las zonas de manipulación.

Introduciendo agua con hielos o agua caliente mantienen la temperatura de las salsas de los dosificador. Facilitan el transporte a las zonas de conservación. Medidas GastroNorm.

100 mm
GN 1/3
325x176 mm



Ref. **01473** + Ref. **01376** / 35 cl

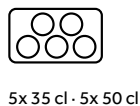

150 mm
GN 1/3
325x176 mm



Ref. **01472** + Ref. **01378** / 75 cl

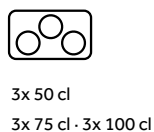

100 mm
GN 1/2
325x265 mm



Ref. **01474** + Ref. **01378** / 75 cl

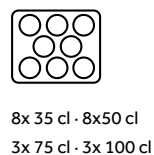

Dispensador para salsas

+95°C +203°F
-40°C -40°F



Dispensador para salsas, aderezos ligeros, jarabes...

Reduce el nivel de mermas, dispensando únicamente la cantidad deseada por bombeo.

Facilidad de carga, permite trasvasar condimentos o aderezos en la cantidad deseada para bombear.

Optimización de espacio: ocupa poco espacio y puede colocarse en la cocina o directamente a disposición del consumidor.

Facilidad de uso: lo puede utilizar el consumidor en la zona de autoservicio.

Mejora la presentación de las salsas en las zonas de Servicio y exposición. Facilitan el transporte a las zonas de conservación.

Bomba desmontable para limpieza

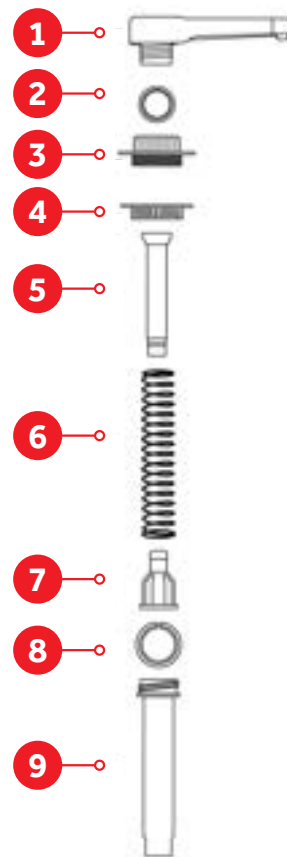

Dispensador para salsas



Facilidad de uso: dispensador en dirección vertical, mayor facilidad para los usuarios y evita derrames accidentales.

Válvula de cierre para mantener todo el circuito de bombeo cerrado para una mejor conservación del producto en el mismo envase, incluso en cámara.

Doble Cierre hermético para una total protección del alimento. La tapa esta fabricada en LDPE material más flexible que permite un correcto ajuste a la base.



Regleta de medición para un perfecto control de las existencias.

ColorClip: Código de color para evitar las contaminaciones cruzadas. Los Contenedores ARAVEN, gracias a su identificación ColorClip, ayudan a prevenir la Contaminación Cruzada, asegurando que el contenido de este recipiente va a ser siempre de la misma naturaleza: aves, carnes rojas, verduras/frutas o pescados.

Etiqueta integrada: La etiqueta permanente permite al profesional de la cocina identificar el contenido y preservar la información asociada a su origen ayudando a cumplir con la Normativa de Trazabilidad Reg (CE) 852/2004 y Reg (CE) 178/2002 referentes a los alimentos.

Medidas GastroNorm: Productos diseñados y fabricados según dimensiones y especificaciones establecidos en la Norma EN 631.1.

GN 1/9
176x108xh190 mm

GN 1/6
176x162xh190 mm

GN 1/4
265x162xh190 mm



x1 - 10 ml



Ref. **03784**



Ref. **03785**



Ref. **03786**



Ref. **03787**



x1 - 30 ml



Ref. **02784**



Ref. **01362**



Ref. **01367**



Ref. **01358**



Ref. **01363**
380x225xh195 mm
+ 3 Ref. **01362**



Ref. **01361**
380x225xh195 mm
+ 2 Ref. **01367**



Ref. **01360**
354x325xh195 mm
+ 3 Ref. **01362**



Ref. **01359**
354x325xh195 mm
+ 2 Ref. **01367**



Grifo para líquidos



Regleta de medición facilita información sobre el consumo y permite realizar mezclas directamente en el recipiente.

Máximo control para dispensar líquidos: llave regulable que controla el caudal.

Asidores laterales que facilitan su manejo y transporte.



Ref. **01368** / 18L
285x285xh320 mm



Ref. **02368**
85x55xh45 mm

Jarra medidora



1L
ø116xh164 mm

2L
ø147xh215 mm

3L
ø157xh243 mm



Ref. **01364**



Ref. **01365**



Ref. **01366**



Ref. **02364**



Ref. **02365**



Ref. **02366**





Cubetas sin tapa

+95°C | +203°F
-40°C | -40°F



+90°C | +194°F
-40°C | -40°F



Las cubetas sin tapa para los procesos de Manipulación están fabricadas en Polietileno por tener buena resistencia al impacto y óptimo comportamiento a bajas temperaturas. Su gran espesor de pieza les proporciona robustez y un buen comportamiento mecánico.

Se recomienda evitar descongelar sin embalaje original y colocando el alimento en cubetas para favorecer una descongelación más rápida.

Para evitar la contaminación cruzada del exudado que se desprende en la descongelación se recomienda la utilización de rejillas a través de la cual se separa el líquido del propio alimento.

En los procesos de descongelación los alimentos deben colocarse en rejillas de altura idónea que se adaptan a las dimensiones del fondo del contenedor y que separen el exudado del propio alimento, ya que este exudado contiene humedad y nutrientes que favorecen la aparición de bacterias que deterioran el alimento.



Cubetas sin tapa



Óptima geometría: Diseño y altura que permite una correcta evacuación del exudado. Cumplen con la normativa higiénico-sanitaria que recomienda evitar el contacto entre el alimento y el exudado.

Cantos redondeados: Su especial diseño evita que se acumulen restos y facilita la limpieza.

Ergonomía: Su borde ergonómico facilita el manejo. Cubetas hondas provistas de asas laterales.

Cubetas sin tapa GastroNorm

+90°C | +194°F
-40°C | -40°F



65 mm

100 mm



GN 1/1
530x325 mm

Ref. **00282** / 9 L

Ref. **00283** / 13 L

Ref. **00256** / 470x265xh20



Harinero
con tapa

Ref. **00290**



03171 01170 01171

+95°C | +203°F
-40°C | -40°F



+90°C | +194°F
-40°C | -40°F



2 L

3 L

5 L

8 L

10 L



Ref. **14129**
300x205xh60 mm



Ref. **14130**
345x235xh75 mm



Ref. **14131**
435x285xh80 mm



Ref. **75132**
485x335xh80 mm



Ref. **75133**
540x385xh80 mm



Ref. **01129**
300x205xh60 mm



Ref. **01130**
345x235xh75 mm



Ref. **01131**
435x285xh80 mm



Ref. **01132**
485x335xh80 mm



Ref. **01133**
540x385xh80 mm



Ref. **01179**
370x215xh10 mm



Ref. **01180**
416x262xh10 mm

20 L

25 L

35 L



Ref. **01134**
440x350xh160 mm



Ref. **01170**
530x396xh139 mm



Ref. **01171**
530x396xh205,5 mm



Ref. **01182**
375x300xh12 mm



Ref. **01178**
432x332xh12 mm



Ref. **03171**
530x396xh205,5 mm



Bowls y escurridores



Los Bowls ARAVEN son una herramienta imprescindible para la Manipulación de alimentos en la cocina.

Disponibles en una gran variedad de tamaños que se adaptan a cada necesidad, con capacidades desde 0,5 L hasta 11 L.

Los escurridores son de gran utilidad para separar los alimentos del líquido. El material del que están fabricados permite una alta resistencia a altas temperaturas y una larga vida útil del producto. Su espesor dota a la pieza de una gran robustez.

Bowls y escurridores

+95°C | +203°F
-40°C | -40°F



Cantos redondeados: Su especial diseño evita que se acumulen restos y facilita la limpieza. Permite el lavado en lavavajillas.

Ergonomía: Su borde ergonómico facilita el manejo. Cubetas hondas provistas de asas laterales.

Encajable.

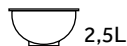
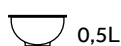

Ref. **01070**
ø 130xh60 mm



Ref. **01071**
ø 170xh80 mm



Ref. **01072**
ø 235xh110 mm



Ref. **01073**
ø 280xh140 mm



Ref. **01074**
ø 325xh160 mm



Ref. **01075**
ø 380xh180 mm



Ref. **91072**
ø 235xh110 mm



Ref. **91073**
ø 280xh140 mm



Ref. **91074**
ø 325xh160 mm



Ref. **91075**
ø 380xh180 mm



Ref. **09515**
ø 235xh110 mm



Ref. **09510**
ø 280xh140 mm



Ref. **09511**
ø 325xh160 mm



Ref. **09512**
ø 380xh180 mm



Ref. **01082**
ø 235xh105 mm



Ref. **01076**
ø 235xh120 mm



Ref. **01083**
ø 280xh123 mm



Ref. **00483**
ø 380xh172 mm



Ref. **01121**
298x228xh112 mm



Ref. **01123**
400x298xh130 mm

Ref. **00679** / 12L
ø 290xh290 mm



Ref. **00252** / 5L
ø 310xh120 mm



Ref. **00253** / 8L
ø 355xh140 mm

+90°C | +194°F
-40°C | -40°F



Tapas de silicona redondas



La flexibilidad de la silicona permite que las tapas se adapten a diferentes materiales y superficies.

Las tapas de silicona redondas ARAVEN permiten conservar los alimentos con todas las garantías higiénico-alimentarias necesarias. Con su efecto vacío puedes extraer parcialmente el aire del recipiente, lo que permite proteger el alimento con mayor garantías, alargando la vida útil del alimento y sin desprender olores. La tapa queda estirada y tensionada lo que permite el apilamiento.

Tapando diferentes recipientes: bolws, cacerolas, platos, etc. Compatible con todos los materiales Polipropileno, Policarbonato, acero, porcelana, vidrio... La tapa se ajusta al borde del recipiente asegurando una total hermeticidad del producto. Puedes cocinar, calentar o regenerar tanto en el horno como en el microondas.

Se puede utilizar en un horno hasta 200 grados y también permite el uso en un microondas, reduciendo el tiempo de cocción y consiguiendo un ahorro energético.

	Ref. 09985 ø 133xh22 mm	Ref. 91003 ø 235xh30 mm	Ref. 91004 ø 285xh33 mm	Ref. 91005 ø 332xh35 mm
	ø133mm - ø153 mm	ø239mm - ø259 mm	ø286mm - ø306 mm	ø332,5mm - ø352,5 mm
Bowls PP				
	Ref. 01070	Ref. 01072	Ref. 01073	Ref. 01074
Bowls PP				
		Ref. 01072	Ref. 01073	Ref. 01074
Bowls PC				
	Ref. 09515	Ref. 09510	Ref. 09511	Ref. 09512



Servicio y exposición



ARAVEN cuenta con una amplia gama de productos para el servicio y exposición de alimentos en la que se ha cuidado el diseño y la funcionalidad para satisfacer las expectativas tanto del personal de servicio como del de cocina.

Las bandejas ARAVEN sirven para cualquier tipología de alimentos y se adaptan a distintas capacidades dada la gran variedad de medidas y acabados:

- Bandejas de exposición con alto brillo y alta transparencia, consiguiendo una gran presencia para una correcta presentación de los alimentos.
- Bandejas de servicio con robustez y resistencia diseñadas para su fácil y rápida limpieza.
- Bandejas y vitrinas expositoras GastroNorm cómodas de usar y que optimizan el espacio.
- Vajilla de Catering reutilizable con un diseño moderno, innovador y atractivo. Los productos tienen un acabado estético excelente, con un elegante diseño y siguiendo las últimas tendencias de cocina en el sector de catering.
- Los vasos y jarras de policarbonato irrompibles, brillantes, transparentes, muy ligeros, reutilizables, duraderos y recomendables para un entorno de terraza y jardín, y restauración de colectividades.

Proteger de la exposición ambiental todos los alimentos procesados hasta el momento de su consumo. La aplicación de un tratamiento térmico a un alimento no garantiza que no haya una contaminación posterior.

Mantener los alimentos elaborados a temperatura igual o superior a 65 °C. Comprobar la temperatura con regularidad.

- El tiempo de mantenimiento en caliente no debe superar las 3 horas.
- Si la temperatura del sistema de conservación en caliente es inferior a 65 °C, se debe proceder al recalentamiento de la elaboración a una temperatura superior a 75 °C y a la revisión del equipo.
- Se recomienda la utilización de tapas o elementos que eviten derrames de las preparaciones en los equipos/contenedores de conservación isotérmica que puedan generar una contaminación posterior.
- Se debe minimizar el tiempo de permanencia a temperatura ambiente de productos elaborados que vayan a consumirse en frío (máximo 30 minutos).

Mantener la cadena de frío de los alimentos elaborados hasta su cocción, recalentamiento o servicio.



Bandejas de 5 compartimentos



Las bandejas autoservicio de ARAVEN contienen los alimentos sin necesidad de usar platos.

Están dotadas de cinco compartimentos: dos grandes para platos principales, dos pequeños para postres, fruta, pan, vaso... y un hueco central rectangular para posicionar los cubiertos.

Los huecos para el alimento van provistos de unos alojamientos laterales para que los cubiertos no se resbalen al interior del hueco.

Sus asidores laterales facilitan el agarre de la bandeja y su transporte incluso para los usuarios de menor edad. Además, se puede tapar la bandeja que contiene los alimentos con solo girar otra bandeja vacía y posicionándola de tapa. Protege los alimentos hasta el momento de ser ingeridos.



- A · x2 · 617 cl
- B · x2 · 197 cl
- C · x1

Bandejas de 5 compartimentos



Bandejas con **diseño ergonómico**. Alojamiento de cubiertos en uso. Permite **tapar bandeja con bandeja**. **Apilables**.

200x150xh12 mm

Tapa de Apoyo



Ref. 31052



Ref. 01052



Ref. 91052



Ref. 81052 + Ref. 31052
Ref. 91052



Ref. 41050



Ref. 61050

Tapa de Apoyo



Ref. 31050



Ref. 21050



Ref. 91050



Ref. 81050 + Ref. 31050
Ref. 91050

Carro de bandejas 5 compartimentos

INOX



x28uds.
Ref. 81052 / 81050

x28uds.
Ref. __052 / __050

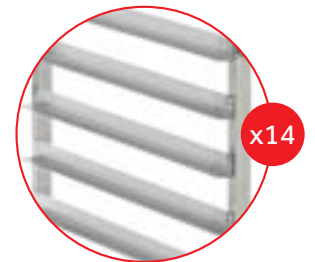
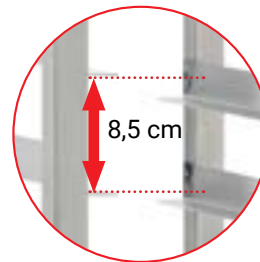

MAX
112kg

Ref. 61224
750x430xh1540 mm



Bandejas de servicio y exposición



Un tipo de bandeja para cada necesidad.

La línea de bandejas de servicio ARAVEN están fabricadas en Polipropileno, un material muy resistente que las hace ideales para restaurantes de servicio rápido, autoservicio y restauración de colectividades.

La misma pieza tiene la superficie texturizada para evitar el deslizamiento del contenido. Son encajables y van provistas de unos puntos de apoyo que permiten la recirculación del aire entre bandejas mientras están apiladas, lo que favorece un correcto secado.

Las bandejas planas, hondas y expositoras de ARAVEN están fabricadas en SAN, material muy transparente cuando no va coloreado y lo que dota a la pieza de una gran visibilidad y brillo. Cuando es mezclado con colorante se consigue además una gran presencia, requisito indispensable para el proceso de exposición. Es rígido pero más frágil que el resto de materiales. Una gama pensada para exponer cualquier tipología de alimentos y que se adapta a distintos tipos de alimentos dada la gran variedad de medidas y de acabados.

Todas las bandejas están diseñadas sin aristas y con cantos redondeados que facilitan su limpieza permitiendo su lavado en el lavavajillas.

Bandejas de servicio y exposición

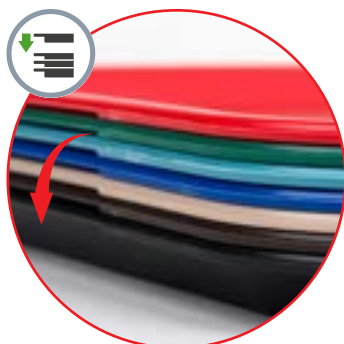

Bandejas encajables provistas de puntos de apoyo que permiten la **circulación del aire entre bandejas** mientras están apiladas, lo que favorece un correcto secado.

Superficie texturizada para **evitar el deslizamiento** del contenido. **Espacio para personalización** con serigrafía



350x270xh20 mm	● Ref. 18046	● Ref. 19046	● Ref. 17046	● Ref. 41046	● Ref. 61046	● Ref. 22046	● —
416x305xh22 mm	● Ref. 18047	● Ref. 19047	● Ref. 17047	● Ref. 41047	● Ref. 61047	● Ref. 22047	● —
458x355xh25 mm	● Ref. 18048	● Ref. 19048	● Ref. 17048	● Ref. 41048	● Ref. 61048	● Ref. 22048	● —
530x370xh25 mm	● Ref. 79049	● Ref. 59049	● Ref. 39049	● Ref. 49049	● Ref. 69049	● Ref. 29049	● Ref. 19049

Carro de bandejas

INOX



Bandejas de servicio



x28 uds.
Ref. __046



x14 uds.
Ref. __048



x14 uds.
Ref. __049



x14 uds.
Ref. __052 / __050

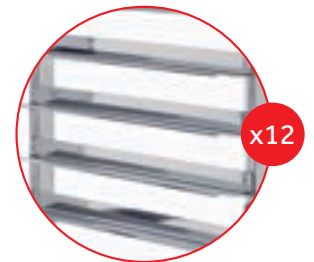
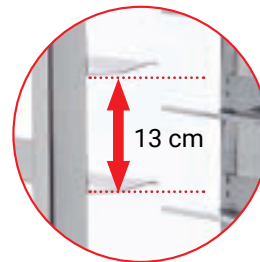

MAX
112kg

Ref. 61216
550x430xh1845 mm



Bandejas de exposición



200x150xh12 mm 280x190xh12 mm 350x240xh12 mm 420x300xh12 mm 500x360xh12 mm

Bandejas planas



Ref. **01021** Ref. **01022** Ref. **01023** Ref. **01024** Ref. **01225**

Ref. **41021** Ref. **41022** Ref. **14023** Ref. **14024** Ref. **41225**

280x200xh15 mm 350x250xh20 mm 420x300x25 mm

Bandejas expositoras



Ref. **01016** Ref. **01017** Ref. **01018**

Ref. **14016** Ref. **14017** Ref. **14018**

200x150xh40 mm 280x190xh40 mm 350x240xh40 mm

Bandejas hondas



Ref. **01040** Ref. **01041** Ref. **01042**

Ref. **41040** Ref. **41041** Ref. **41042**

Expobandeja GastroNorm

+90°C | +194°F
-40°C | -40°F



Bandejas con tapa de protección para pasar de exposición a conservación en un solo paso (basta con colocar la tapa).

Cierre por clip: Su cierre por clip permite una conservación máxima de los alimentos. Optimización del espacio, **apilamiento de bandejas con tapa**. Apoyos de secado rápido. Permite la **libre circulación del aire entre las bandejas** para favorecer el secado. La Expobandeja incorpora **tapa transparente** para una rápida visualización del contenido.



GN 1/1
530x325xh36 mm

Ref. **00291** / 2+2 L

Expovitrinas GastroNorm

+90°C | +194°F
-40°C | -40°F



Las expovitrinas ARAVEN GN 1/2 y GN 1/1 cuentan con bandejas y campanas de protección para pasar de exposición a conservación en un solo paso. (basta con colocar la tapa).



GN 2/1
325x265xh118 mm

Ref. **00288** / 1+6 L



GN 1/1
530x325xh82 mm

Ref. **00289** / 2+9 L

Cubreplatos



En los establecimientos de autoservicio, el modo de exposición deberá ser tal que los alimentos ofrecidos estarán protegidos contra la contaminación directa que podría derivar de la proximidad o la acción del consumidor.

El cubreplatos ARAVEN es irrompible y protege el alimento de posibles contaminaciones externas manteniéndolo cubierto hasta el momento de servicio. Además en cocina permite apilar varios platos optimizando el espacio hasta el momento del servicio. Los cubreplatos ARAVEN permiten conservar la comida caliente hasta el momento de su servicio. Provista de un agujero central para evitar la condensación y facilitar su apertura.

Su transparencia permite una rápida identificación de los alimentos. Cinco modelos para adaptarse a los diferentes contornos de platos que van desde Ø 215 hasta Ø 315.



Ref. **99484**
Ø 215xh67 mm



Ref. **99485**
Ø 240xh67 mm



Ref. **99486**
Ø 265xh67 mm



Ref. **99891**
Ø 290xh67 mm



Ref. **99892**
Ø 315xh67 mm



Ref. **09484**
Ø 215xh67 mm



Ref. **09485**
Ø 240xh67 mm



Ref. **09486**
Ø 265xh67 mm



Ref. **09891**
Ø 290xh67 mm



Ref. **09892**
Ø 315xh67 mm

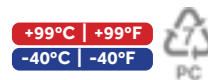



Vajilla catering



Modernas, innovadoras y atractivas...así son las vajillas de catering NATURE y WAVE Catering System de ARAVEN. Un producto de cuidado diseño y acabado estético excelente siguiendo las últimas tendencias de cocina en el sector de catering.

Fabricado en Poliestireno de alta densidad (PS). 100 % reciclable, material de excelente presencia, brillo y acabado superficial propio de un servicio de catering de alta gama.

Se presenta la gama en tres propuestas de color: transparente, blanco y negro. La pieza y el alimento en la exposición se complementan encontrando un equilibrio entre las dos para conseguir una impecable presentación con la que resaltar la originalidad de las creaciones culinarias más vanguardistas.

Por su capacidad el alimento se puede degustar en uno o dos bocados y sus formas redondeadas permiten acceder a la totalidad de su contenido.

ERGONÓMICA Y VERSÁTIL

Las piezas de la gama permiten múltiples combinaciones de color y forma (encaje del vaso sobre el plato con el fin de sujetar los dos elementos en una sola mano. El platito plano con platito hondo ...). Fácil apilamiento para optimizar el espacio en vacío en toda la familia.



Vajilla de catering

+90°C | +194°F
-40°C | -40°F



- Ref.
○ Ref. **01** ___
● Ref. **41** ___
◐ Ref. **91** ___



wave
CATERING SYSTEM



Ref. **__770**
90x22xh4 mm



Ref. **__769**
121x42xh20 mm



Ref. **91760** / 5cl
51x51xh33 mm



Ref. **__761** / 9cl
51x51xh55 mm



Ref. **__763** / 7cl
70x70xh23 mm



Ref. **__765** / 25cl
107x107xh35 mm



○ Ref. **__762**
● Ref. **__762**
80x80xh15 mm



Ref. **__764**
127x127xh15 mm



Ref. **__766**
280x280xh15 mm



Ref. **__768**
200x70xh8 mm



Ref. **__767**
480x240xh17 mm

Vajilla de catering



- Ref.
 ○ Ref. 01 ___
 ● Ref. 41 ___
 ● Ref. 91 ___



nature
catering system



Ref. __739
98x20xh11 mm



Ref. __734
119x40xh20 mm



● Ref. 91735 / 5cl
56xh43 mm



Ref. __736 / 9cl
60xh64 mm



Ref. __745 / 8 cl
90x84xh32 mm



Ref. __744
97x79xh15 mm



Ref. __743
104x160xh18 mm



● Ref. 91742
340x209xh19 mm



Vasos, copas y jarras



Perfectos para uso colectivo en festivales, piscinas y establecimientos de alojamientos turísticos donde se recomienda el uso de vajillas de materiales irrompibles.

La gama de vasos de ARAVEN disponen de un amplio rango de capacidades. Irrompibles, transparentes y manejables.

Son reutilizables, minimiza el impacto ambiental al generar menor cantidad de residuos en comparativa con el vaso desechable. Su diseño está en línea con las tendencias en vajilla utilizada en restauración con un efecto visual similar al cristal.

Personaliza con tu marca

Los vasos de ARAVEN son personalizables con serigrafía o grabado. También existe la posibilidad de combinar diseño de personalización de grabado con serigrafía.

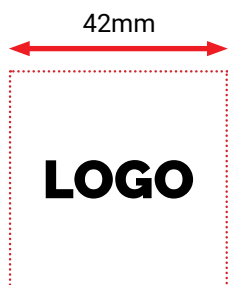

LOGO:
Tamaño Max. 42x42 mm
Max. 2 colores
Min. 200 unidades





Vasos



25cl. ø71xh98 mm	40cl. ø82xh114 mm	56cl. ø92xh127 mm	25cl. ø 82xh62 mm	40cl. ø 85xh90 mm	56cl. ø 89xh119 mm	33cl. ø81xh142 mm	30cl. ø59xh154,5 mm
---------------------	----------------------	----------------------	----------------------	----------------------	-----------------------	----------------------	------------------------



25cl. ø71xh98 mm	40cl. ø82xh114 mm	56cl. ø92xh127 mm	25cl. ø 82xh62 mm	40cl. ø 85xh90 mm	56cl. ø 89xh119 mm	33cl. ø81xh142 mm	30cl. ø59xh154,5 mm
---------------------	----------------------	----------------------	----------------------	----------------------	-----------------------	----------------------	------------------------



Vasos, copas y jarras

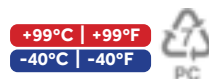

6cl.
ø47x76 mm

42cl.
ø87xh97 mm

54cl.
ø77xh157 mm

45cl.
ø 80x256 mm

60cl.
ø 82x150 mm

70cl.
ø 86xh255 mm

70cl.
ø145x104xh155 mm



Ref. 91660



Ref. 91643



Ref. 91642



Ref. 91661



Ref. 91662



Ref. 91641



Ref. 91659



6cl.
ø47x76 mm

42cl.
ø87xh97 mm

54cl.
ø77xh157 mm

45cl.
ø 80x256 mm

60cl.
ø 82x150 mm

70cl.
ø 86xh255 mm

70cl.
ø145x104xh155 mm



Ref. 41660



Ref. 41643



Ref. 41642



Ref. 41661



Ref. 41662



Ref. 41641



Ref. 41659

Vasos, copas y jarras

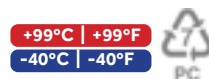

28cl.
ø79xh188 mm

33cl.
ø84xh212 mm

18cl.
ø67,7xh222 mm

30cl.
ø119xh169 mm

78cl.
ø117xh210 mm



Ref. 91646



Ref. 91647



Ref. 91648



Ref. 91644



Ref. 91649



28cl.
ø79xh188 mm

33cl.
ø84xh212 mm

18cl.
ø67,7xh222 mm

30cl.
ø119xh169 mm

78cl.
ø117xh210 mm



Ref. 41646



Ref. 41647



Ref. 41648



Ref. 41644



Ref. 41649



Accesorios de Buffet



Ideales para exponer en mesas de buffet y estaciones de alimentos. Máxima resistencia, fabricados en PC.

Pinzas ideales para servir alimentos calientes y fríos. Diseño ergonómico que facilita el agarre de alimentos difíciles de servir como verduras o ensaladas. Las pinzas planas aseguran un perfecto agarre del alimento.

Cucharones con control de porción para servir la cantidad deseada de aderezo. Diseñados con una hendidura lateral de tal manera que ayuda a que los cucharones no se deslicen hacia el interior de los recipientes.

Cucharas. Su diseño ergonómico con una hendidura en la parte trasera que ayuda a alojar la cuchara sobre el recipiente para evitar que caiga en el interior del recipiente. Ideales para preparar y servir alimentos calientes o fríos.





Jarras Apilables



Soluciones prácticas y seguras para el servicio de bebidas

Las jarras apilables ARAVEN son encajables sin tapa para optimizar el espacio de almacenamiento cuando no está en uso. El diseño exclusivo de su tapa, además de proteger el contenido de la jarra de contaminaciones externas, tiene una doble posición para permitir: Apertura de la jarra con rejilla que evita la caída de los hielos y cierre para transportar la jarra con seguridad en comedores.





_1400 _1401 _1402 _1403



Tapas 119x119x41 mm



Ref. 01400



Ref. 21400



HDPE



+90°C | +194°F
-40°C | -40°F



+95°C | +203°F
-40°C | -40°F



+80°C | +176°F
-40°C | -40°F



1L
167x119x130 mm



Ref. 21401



Ref. 31401



Ref. 01401



Ref. 11401



Ref. 71401



1,4L
167x119x180 mm



Ref. 21402



Ref. 31402



Ref. 01402



Ref. 11402



Ref. 71402



1,8L
167x119x232 mm



Ref. 21403



Ref. 31403



Ref. 01403



Ref. 11403



Ref. 71403

Servicio de mesa



La Jarra de material irrompible evita riesgos innecesarios en comedores de uso colectivo destinados a la alimentación de grandes grupos de personas.

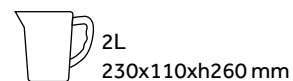
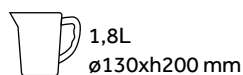
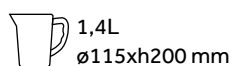

ABS
Ref. 91006



ABS
Ref. 91007



SAN
Ref. 02080



PC
Ref. 09673



PC
Ref. 09674

Servicio de mesa



Ref. **01068**
ø97xh137 mm



Ref. **01475**
325x265xh150 mm



Ref. **01064**
156x81xh131 mm



Ref. **01037**
366x297xh60 mm



Ref. **02038**
ø115xh140 mm



Ref. **01010**
280x110xh48 mm



Ref. **02077**
160x130xh105 mm



Ref. **02037**
ø112xh25 mm



Ref. **01049**
212x138xh21 mm



Portacubiertos



Los portacubiertos te permitirán mantener los cubiertos limpios y ordenados, después del proceso de lavado y secado hasta el momento de su posicionamiento en mesa para el servicio.

El portacubiertos de ARAVEN de 4 compartimentos y medidas GastroNorm 1/1 permiten su compatibilidad con el resto de las instalaciones de establecimiento. El portacubiertos con tapa protege los utensilios en sala hasta de la exposición ambiental el momento de su uso.



- 4 x 60 4 x 110
- 4 x 35 4 x 60
- 4 x 35 4 x 30



Ref. **09863** / GN1/1
530x325xh100 mm



Ref. **41128** / GN1/1
530x325xh100 mm

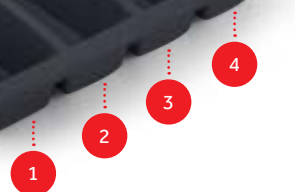

Manopla de silicona



Ref. **31213**
153x124xh71 mm

Box Display
309,5x217xh333 mm



Ref. **31211**
153x124xh71 mm

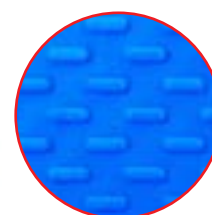

Texturizado interior que facilita el agarre y protege de las altas temperaturas.



Carros de servicio y accesorios

+150°C | +302°F
-25°C | -13°F



+95°C | +203°F
-40°C | -40°F



Uno de los puntos clave en el servicio de restauración es el montaje de las mesas.

El montaje del comedor en un restaurante consiste en dos partes: la preparación y repaso del material y otra el montaje de las mesas. Normalmente, este trabajo se efectúa a la vez. Para el montaje ayudarse de un carro auxiliar permitirá optimizar los tiempos de montaje al reducir el número de desplazamientos y tener a mano todo el material preparado. Otra de las ventajas de utilizar un carro de servicio es evitar riesgos laborales al no tener que soportar los pesos de estos materiales, muchos de ellos pesados como las vajillas, cuberterías o menaje.

Un carro de servicio no solo será de gran ayuda en el montaje de las mesas. Su versatilidad te será muy útil también en el desmontaje de mesas así como en trabajos de logística para la recepción y distribución de mercancía, transporte en el interior del establecimiento o servicio de habitaciones como carro camarera.



MAX
150kg

Ref. 61217
1070x500xh980 mm



MAX
150kg

Ref. 61221
950x500xh945 mm

Cubetas

+95°C | +203°F
-40°C | -40°F



Cubetas negras utilizadas para el montaje y desmontaje del comedor, para transportar y recoger la vajilla o cristalería.

El color oscuro impide que los comensales visualicen el interior de las cubetas con los desperdicios.

Recomendamos que las cubetas con esta finalidad sean de diferente color (negro) a las cubetas blancas o transparentes que están en contacto con alimentos utilizadas en cocina y seguir así unas normas higiénico-sanitarias óptimas.

El cubo negro para desechos y el recipiente para cubiertos sucios se pueden alojar en los cuatro lados exteriores del carro para facilitar el vaciado del contenido de los platos.

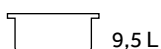

9,5 L



28,5 L



Ref. **61218**
330x230xh175 mm



Ref. **61219**
330x230xh560 mm

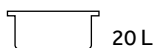

20 L

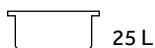

25 L

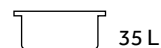

35 L



Ref. **71134**
440x350xh160 mm



Ref. **71170**
530x396xh139 mm



Ref. **71171**
530x396xh205,5 mm

Organizadores



Cajoneras para mantener el orden

Las cajoneras apilables ARAVEN mantiene en orden en el carro y al ser translúcidas permiten encontrar rápidamente cualquier utensilio.

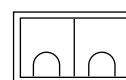
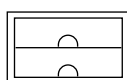
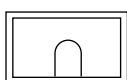

Ref. **07500**
350x260xh145 mm



Ref. **07498**
350x260xh145 mm



Ref. **07499**
350x260xh145 mm



Ref. **07501**
450x349xh195 mm



Ref. **07502**
450x349xh195 mm



Ref. **07503**
450x349xh195 mm



Transporte



La cadena de frío, elemento clave en seguridad alimentaria. La cadena de frío es el conjunto de pasos necesarios tras el proceso de refrigeración o congelación de los alimentos para que éstos lleguen de forma segura al consumidor. Incluye todo un conjunto de elementos y actividades necesarias para garantizar la calidad y seguridad de un alimento, desde su origen hasta su consumo.

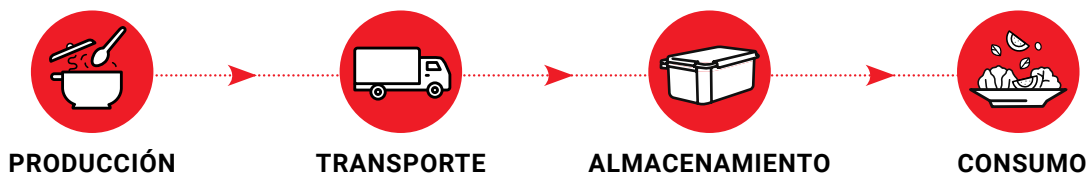

Objetivo: Proteger los alimentos conservándolos a temperatura adecuada durante el transporte para evitar la multiplicación de microorganismos que puedan afectar a la calidad y seguridad de los alimentos.



Congelados -18°C



Fresco 6°C

La pérdida de la temperatura óptima de refrigeración o congelación en cualquiera de las etapas perjudica la seguridad y calidad del alimento. Cuando el alimento debe llegar a su lugar de destino a temperatura de servicio, (65°) puede realizarse el transporte en caliente. En este caso será clave mantener los alimentos con las mínimas variaciones durante su período de vida comercial útil. El transporte que se realizará en vehículos o medios preparados para mantener la temperatura del producto con la mínima variación.

Armario isotérmico GastroNorm



Transporte de pre elaborados o elaborados con un absoluto control de cadena de frío y calor.

Transporte de pre elaborados o elaborados garantizando el mantenimiento de las óptimas condiciones de temperaturas durante el transporte, con un absoluto control de cadena de frío y calor.

El Armario Isotérmico ARAVEN es ligero y resistente, protege los alimentos de cambios térmicos garantizando un absoluto control de las cadenas de frío y calor.



Conservación en caliente: cada hora la temperatura disminuye 2°C



Conservación en frío: cada una hora la temperatura aumenta 0,5°C

Optimización del espacio

Apilamiento entre módulos con tapa.



Almacenamiento entre módulos en vacío.

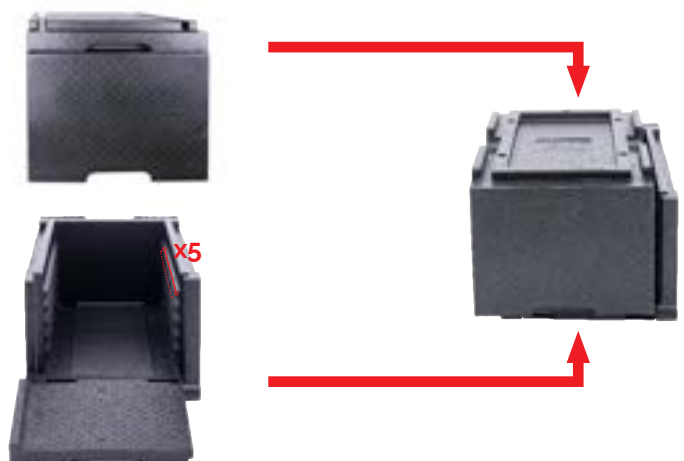

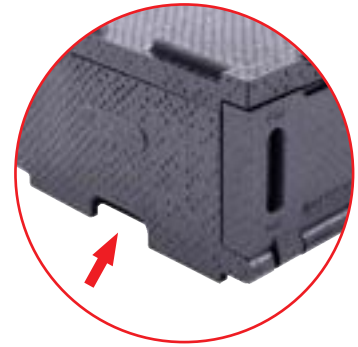

Doble accesibilidad: Apertura superior y frontal permitiendo realizar la carga y descarga con la máxima accesibilidad, comodidad y rapidez. **Puerta frontal abatible** incluso con varios contenedores apilados. **Fácil apilamiento.** Asidores integrados. Zonas de agarre lateral.

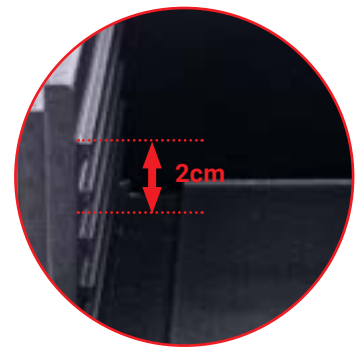

Desmontable fácil limpieza en lavavajillas. Alojamiento laterales para cinchas de transporte. Guías interiores y alojamiento para cubetas GastroNorm:

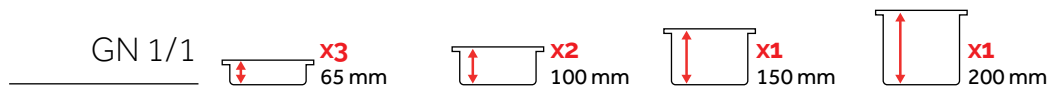

Ref. **41500** / 48 L
657x420xh379 mm
INT. 550x330xh239 mm

Armario isotérmico GastroNorm



Válvula vapor, facilita la evacuación del vapor para evitar condensación. **Asas superiores** de plástico para fijación y transporte. Cierre altamente resistente con junta de caucho que **cierra el armario herméticamente**. Apilables. Guías interiores y alojamiento para cubetas GastroNorm.

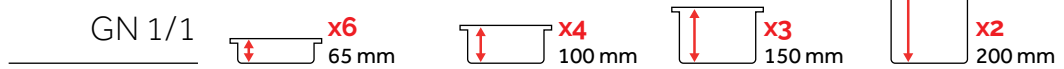
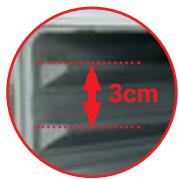

2h ↓ 1° **Conservación en Caliente:** cada dos horas la temperatura disminuye 1°C.

2h ↑ 1° **Conservación en frío:** cada dos horas la temperatura aumenta 1°C.

Ref. **41819** / 90 L
680x477xh620 mm
INT. 533x335xh480 mm

Isotérmico para líquidos



Mantienen las bebidas frías o calientes durante horas. Asas moldeadas integradas. Apilables. 4 cierres laterales. Grifo dispensador de bebidas, antigoteo con dos posiciones: Caudal continuo y caudal regulable.



Ref. **01810** / 9,4 L
420x230xh470 mm

Plataforma GastroNorm



Base con ruedas que Facilita el transporte de los Armarios GN haciéndolo más cómodo y rápido.



Incluye cincha de amarre.



Incluye dos ruedas con freno.



MAX
150kg

Plataforma
con ruedas

Ref. **41818**
760x530xh220 mm

Cubetas con tapa



Etiqueta integrada: La etiqueta Permanente permite al profesional de la cocina identificar el contenido y preservar la información asociada a su origen ayudando a cumplir con la Normativa de Trazabilidad Reg (CE) 852/2004 y Reg (CE) 178/2002 referentes a los alimentos.

ColorClip: Código de color para evitar las contaminaciones cruzadas. Los Contenedores ARAVEN, gracias a su identificación ColorClip, ayudan a prevenir la Contaminación Cruzada, asegurando que el contenido de este recipiente va a ser siempre de la misma naturaleza: aves, carnes rojas, verduras/frutas o pescados.

Apilables con tapa y **encajables** en vacío. **Asidores laterales**, con cierre para facilitar su manejo y transporte.



+

Ref. **03171**
Ref. **__173** ■ 6,8 L



+

Ref. **03171**
Ref. **__183** ■ 23 L



+95°C | +203°F
-40°C | -40°F



+90°C | +194°F
-40°C | -40°F



Rotulador
HORECA
Pág. 57



Cubeta
Perforada
Pág. 121

Ref. **03171**



Rejillas
Pág. 51

Ref. **01178**



Ref. **01178**



Ref. **01180**

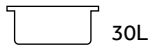

30L

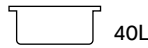

40L

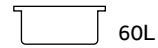

60L

Ref.

○ Ref. **01** ___

Ref. **__172**

● Ref. **91** ___

530x396xh159 mm



Ref. **__173**

530x396xh225,5 mm



Ref. **__183**

530x396xh378,5 mm

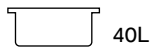

40L

Cubetas con tapa

+95°C | +203°F
-40°C | -40°F



○ Ref. **00545**

830x460xh180 mm



Ref. **91184** / 9 L

380x265xh155 mm



Ref. **91185** / 14 L

380x265xh230 mm



Cierres laterales de tapa.

Asidores laterales para facilitar su manejo y el transporte.

Food Bacs

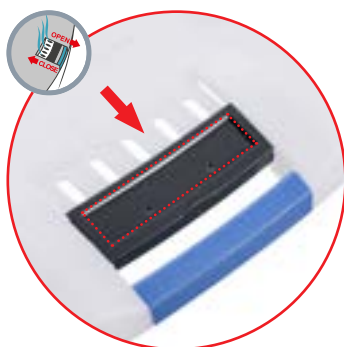
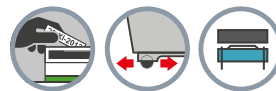

Ventilación: Trampillas de ventilación para alimentos con alto contenido en humedad: frutas y verduras. Garantiza la re-circulación del aire en el transporte de alimentos y permite eliminar el agua evaporada sin que se dé la condensación.

Alojamiento para la ubicación de identificador del contenido del interior.

ColorClip: Código de color para evitar las contaminaciones cruzadas.



Encajables sin tapa, optimizan el espacio en vacío. **Apilables con tapa.**

Ruedas resistentes en poliamida en los tamaños de 70L y 90L para facilitar el transporte.

Cierres metálicos laterales en los tamaños de 70L y 90L, aseguran el cierre de la tapa.

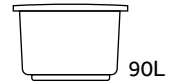
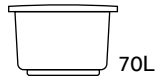
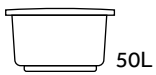

Ref. **01850**
600x395xh410 mm



Ref. **01870**
655x435xh455 mm



Ref. **01890**
705x465xh480 mm



Limpieza



El cubo de basura en la cocina puede ser un foco de contaminación y un lugar idóneo para la proliferación bacteriana. Para evitar poner en riesgo la seguridad alimentaria de la zona de manipulación de alimentos, se deben de utilizar cubos de basura con tapa y apertura no manual.

Deberán de estar ubicados en zonas especialmente diseñadas para tal uso, evitando el contacto con los productos alimenticios. Los recipientes de basura deberán de estar contruidos con materiales resistentes, de fácil limpieza y desinfección, para garantizar su buen estado de higiene.

Los cubos de basura ARAVEN son aliados fundamentales en la implantación de sistemas APPCC en procesos de limpieza. Su tapa se acciona por pedal, lo que permite depositar la

basura sin que las manos entren nunca en contacto con el cubo, ayudando a no contaminar con ellas otras zonas de trabajo, ni los alimentos posteriormente manipulados.

Además, su resistente material permite ser limpiados y en caso necesario, desinfectados para realizar un correcto mantenimiento de la zona de la basura, impidiendo cualquier proliferación bacteriana.

ARAVEN dispone de cubos específicos para cada tipo de desecho, permitiendo la clasificación del residuo generado para su posterior eliminación, sin perjudicar al medio ambiente con arreglo a la normativa comunitaria aplicable a tal efecto. La gama de cubos de basura ARAVEN van desde los 22 litros hasta los 120 litros de capacidad, adaptándose a las necesidades del volumen de residuos generados por la actividad de la cocina.



Cubos reciclados



Cubos fabricados con los residuos generados en nuestra producción. El residuo plástico generado en nuestras plantas de producción es 100% reciclado y se convierte en nuevos productos sin perder sus propiedades. Con esta acción minimizamos la contaminación del medio ambiente.



Recuperación y procesado del

residuo plástico de
nuestra fabricación



Fabricación reutilizando el

100% de los
residuos plásticos



Creamos nuevos productos

con material
100% Reciclado

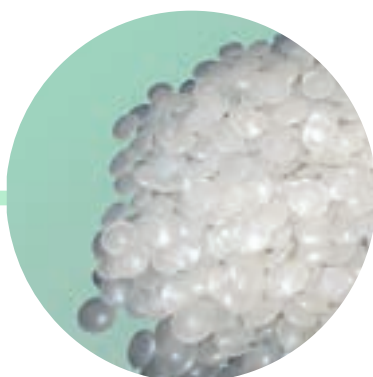

Cubos reciclados



22L

Ref. **40400** / 22L
424x262xh420mm

Ref. **45400** / 22L
424x262xh420mm

Ref. **47400** / 22L
424x262xh420mm

Ref. **46400** / 22L
424x262xh420mm

Ref. **43400** / 22L
424x262xh420mm



22L

Ref. **44400** / 22L
310x335xh420mm





25L



Ref. **40271** / 25L
310x335xh420mm

Ref. **45271** / 25L
310x335xh420mm

Ref. **47271** / 25L
310x335xh420mm

Ref. **46271** / 25L
310x335xh420mm

Ref. **43271** / 25L
310x335xh420mm

25L



Ref. **44271** / 25L
310x335xh420mm

25L



Ref. **08271** / 25L
310x335xh420mm

40L



Ref. **40275** / 40L
435x300h635mm

Ref. **45275** / 40L
435x300h635mm

Ref. **47275** / 40L
435x300h635mm

Ref. **46275** / 40L
435x300h635mm

Ref. **43275** / 40L
435x300h635mm

40L



Ref. **44275** / 40L
310x335xh420mm



Cubos de basura



Con pedal metálico rigidizado: para una mayor resistencia. Este pedal **acciona la apertura de tapa** para evitar todo contacto directo con los desechos depositados en el contenedor de basura.

La tapa permite abrirse totalmente alojándose en la parte trasera del cubo para vaciar la carga con facilidad.

Cubos de **ruedas grandes** con rodadura de caucho que hacen más fácil su transporte.



Ergonomía en su asa que facilita su movilidad.

Codificación de color para reciclaje y recogida selectiva de residuos.

Fabricado en Polietileno de alta densidad (HDPE) que **garantiza su resistencia**.



Ref. **71215** / 50 L
467x435xh620 mm



Ref. **31215** / 50 L
467x435xh620 mm



Ref. **51215** / 50 L
467x435xh620 mm

● Ref. **03** ___ ● Ref. **05** ___ ● Ref. **07** ___ ● Ref. **06** ___



Ref. __ **403** / 80 L
490x520xh655 mm



Ref. __ **404** / 100 L
490x530xh800 mm



Ref. __ **405** / 120 L
490x560xh940 mm

Limpeza e higiene

+95°C | +203°F
-40°C | -40°F



6x

Ref. **40249** / 15L
370x383xh370mm



6x

Ref. **40250** / 12L
ø290xh290mm



6x

Ref. **14660** / 15L
370x383xh370mm



6x

Ref. **14661** / 12L
ø290xh290mm

+95°C | +203°F
-40°C | -40°F



10x

Ref. **61220**
210x300xh630mm



6x

Ref. **42865** / 15L
370x383xh370mm



6x

Ref. **42866** / 12L
ø290xh290mm

+95°C | +203°F
-40°C | -40°F



6x

Ref. **88249** / 15L
370x383xh370mm



6x

Ref. **88250** / 12L
ø290xh290mm

+95°C | +203°F
-40°C | -40°F



Ordenación multiusos



Ref. **00302**
265x180xh185 mm



Ref. **00303**
265x180xh185 mm



Ref. **00301**
350x250xh190 mm



Ref. **00300**
350x250xh280 mm

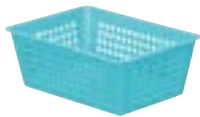

Ref. **81090**
162x119xh58 mm

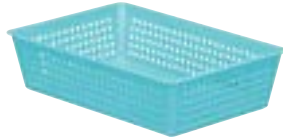

Ref. **81091**
238x160xh58 mm



Ref. **81092**
326x240xh58 mm



Ref. **81093** / 9L
380x265xh155 mm



Ref. **81094** / 14L
380x265xh230 mm





































Ref. **08317** / 17L
530x396xh242 mm









































































Ref. **03315** / 60L
830x460xh180 mm









































































Ref. **91177** / 60L
530x396xh378,5 mm



































		ITEM	EAN13 GTIN-13	Product Dimensions L x W x H (mm)	DUN 14 GTIN-14	Box Dimensions L x W x H (mm)				
PRESERVATION										
		03020	8411777030206	176x108x65	18411777030203	215x185x205	6	20	600	1320
		03021	8411777030213	176x108x100	18411777030210	325x185x203	6	14	420	924
		03022	8411777030220	176x108x150	18411777030227	325x185x305	6	14	252	588
		03023	8411777030237	176x162x65	18411777030234	325x185x203	6	14	420	924
		03024	8411777030244	176x162x100	18411777030241	325x185x305	6	14	252	588
		03025	8411777030251	176x162x150	18411777030258	485x190x310	6	9	162	378
		03026	8411777030268	265x162x65	18411777030265	325x275x206	6	10	300	660
		03027	8411777030275	265x162x100	18411777030272	480x275x207	6	6	180	396
		03028	8411777030282	265x162x150	18411777030289	475x275x310	6	6	108	252
		03029	8411777030299	325x176x65	18411777030296	350x345x210	6	6	180	360
		03030	8411777030305	325x176x100	18411777030302	360x335x310	6	6	108	252
		03031	8411777030312	325x176x150	18411777030319	530x335x320	6	4	72	168
		03032	8411777030329	325x265x65	18411777030326	540x345x230	6	4	96	240
		03033	8411777030336	325x265x100	18411777030333	530x335x320	6	4	72	168
		03034	8411777030343	325x265x150	18411777030340	530x340x350	6	4	72	144
		03035	8411777030350	325x265x200	18411777030357	520x330x410	6	4	48	120
		03469	8411777034693	354x325x100	18411777034690	650x380x415	8	3	48	120
		00470	8411777004702	354x325x150	18411777004709	715x340x415	8	3	48	120
		00471	8411777004719	354x325x200	18411777004716	715x340x455	8	3	48	120
		03044	8411777030442	530x325x65	18411777030449	530x335x320	6	5	90	210
		03036	8411777030367	530x325x100	18411777030364	530x335x435	6	4	48	120
		03037	8411777030374	530x325x150	18411777030371	540x340x540	6	4	48	96
		03038	8411777030381	530x325x200	18411777030388	540x340x545	6	4	48	96
		04010	8411777040106	176x108x165	18411777040103	225x190x135	6	20	960	2040
		04011	8411777040113	176x108x100	18411777040110	225x190x170	6	20	720	1560
		04012	8411777040120	176x108x150	18411777040127	225x185x210	6	20	480	1200
		04015	8411777040151	176x162x65	18411777040158	335x190x155	6	14	588	1176
		04016	8411777040168	176x162x100	18411777040165	320x185x170	6	14	504	1092
		04017	8411777040175	176x162x150	18411777040172	330x185x240	6	14	336	756
		04019	8411777040199	265x162x65	18411777040196	345x285x160	6	8	288	672



































		ITEM	EAN13 GTIN-13	Product Dimensions L x W x H (mm)	DUN 14 GTIN-14	Box Dimensions L x W x H (mm)				
		04020	8411777040205	265x162x100	18411777040202	345x285x195	6	8	240	528
		04021	8411777040212	265x162x150	18411777040219	340x285x240	6	8	192	432
		04025	8411777040250	325x176x65	18411777040257	340x340x155	6	6	252	504
		04026	8411777040267	325x176x100	18411777040264	340x340x185	6	6	180	432
		04027	8411777040274	325x176x150	18411777040271	360x350x23	6	6	144	260
		04034	8411777040342	325x265x65	18411777040349	335x280x260	6	8	192	384
		04035	8411777040359	325x265x100	18411777040356	335x280x229	6	8	192	480
		04036	8411777040366	325x265x150	18411777040363	340x280x345	6	8	144	288
		04037	8411777040373	325x265x200	18411777040370	335x285x410	6	9	108	270
		04058	8411777040588	530x325x65	18411777040585	540x335x225	6	4	96	240
		04059	8411777040595	530x325x100	18411777040592	540x335x290	6	4	72	168
		04060	8411777040601	530x325x150	18411777040608	540x350x345	6	4	72	144
		04061	8411777040618	530x325x200	18411777040615	535x335x395	6	4	48	120
		04073	8411777040731	176x162x130	18411777040738	320x185x205	6	14	420	924
		04075	8411777040755	325x176x130	18411777040752	345x335x195	6	6	180	396
		04076	8411777040762	325x265x130	18411777040769	335x280x270	6	8	192	384
		04078	8411777040786	530x325x130	18411777040783	545x340x300	6	4	72	168
		04013	8411777040137	176x108x13	18411777040134	185x120x105	6	39	2340	4914
		34013	8411777340138	176x108x13	18411777340135	185x120x106	6	39	2340	4914
		04018	8411777040182	176x162x27	18411777040189	180x175x125	6	24	1152	2592
		34018	8411777340183	176x162x27	18411777340180	180x175x126	6	24	1152	2592
		04022	8411777040229	265x162x27	18411777040226	275x175x125	6	18	864	1944
		34022	8411777340220	265x162x27	18411777340227	275x175x126	6	18	864	1944
		04029	8411777040298	325x176x27	18411777040295	330x190x130	6	14	672	1428
		34029	8411777340299	325x176x27	18411777340296	330x190x130	6	14	672	1428
		04038	8411777040380	325x265x27	18411777040387	350x280x130	6	8	384	816
		34038	8411777340381	325x265x27	18411777340388	350x280x130	6	8	384	816
		04062	8411777040625	530x325x27	18411777040622	535x340x125	6	4	192	432
		34062	8411777340626	530x325x27	18411777340623	535x340x125	6	4	192	432
		07390	8411777073906	176x108x13	18411777073903	185x120x106	6	39	2340	4914
		07391	8411777073913	176x162x27	18411777073910	180x175x125	6	24	1152	2592



































	ITEM	EAN13 GTIN-13	Product Dimensions L x W x H (mm)	DUN 14 GTIN-14	Box Dimensions L x W x H (mm)				
	07392	8411777073920	265x162x27	18411777073927	275x175x126	6	18	864	1944
	07393	8411777073937	325x176x27	18411777073934	330x190x130	6	14	672	1428
	07394	8411777073944	325x265x27	18411777073941	350x280x130	6	8	384	816
	07395	8411777073951	530x325x27	18411777073958	535x340x125	6	4	192	432
	03019	8411777030190	165x100x6	18411777030197	230x170x115	60	21	11340	25200
	74010	8411777740105	176x108x65	18411777740102	185x220x130	6	20	960	2040
	74011	8411777740112	176x108x100	18411777740119	225x190x170	6	20	720	1560
	07796	8411777077966	176x162x65	18411777077963	330x190x150	6	14	588	1260
	07797	8411777077973	176x162x100	18411777077970	330x185x203	6	13	390	858
	07798	8411777077980	176x162x150	18411777077987	330x185x240	6	14	336	756
	07816	8411777078161	265x162x65	18411777078168	340x285x150	6	8	336	720
	07817	8411777078178	265x162x100	18411777078175	340x280x190	6	8	240	576
	07818	8411777078185	265x162x150	18411777078182	340x280x240	6	8	192	432
	07808	8411777078086	325x176x65	18411777078083	360x335x160	6	6	216	504
	07819	8411777078192	325x176x100	18411777078199	360x345x190	6	6	180	432
	07820	8411777078208	325x176x150	18411777078205	360x345x240	6	6	144	324
	07831	8411777078314	325x176x200	18411777078311	365x335x290	6	6	108	252
	07821	8411777078215	325x265x65	18411777078212	330x280x255	6	8	192	432
	07822	8411777078222	325x265x100	18411777078229	330x280x290	6	8	144	336
	07823	8411777078239	325x265x150	18411777078236	340x280x345	6	8	144	288
	07834	8411777078345	325x265x200	18411777078342	335x280x400	6	9	108	270
	07826	8411777078260	530x325x65	18411777078267	540x335x225	6	5	120	300
	07827	8411777078277	530x325x100	18411777078274	540x335x290	6	5	90	210
	07828	8411777078284	530x325x150	18411777078281	540x335x340	6	5	90	180
	07835	8411777078352	530x325x200	18411777078359	535x335x395	6	5	60	150
	07825	8411777078253	325x265x150	18411777078250	540x350x345	6	5	90	180
	77784	8411777777842	176x108x65	18411777777849	185x220x175	6	20	720	1560
	77785	8411777777859	176x108x100	18411777777856	185x220x205	6	20	600	1320
	07781	8411777077812	176x162x65	18411777077819	330x190x210	6	14	420	924
	07782	8411777077829	176x162x100	18411777077826	330x185x225	6	14	336	840
	07783	8411777077836	176x162x150	18411777077833	330x190x280	6	14	252	672





































	ITEM	EAN13 GTIN-13	Product Dimensions L x W x H (mm)	DUN 14 GTIN-14	Box Dimensions L x W x H (mm)				
	07767	8411777077676	265x162x65	18411777077673	340x280x190	6	8	240	576
	07768	8411777077683	265x162x100	18411777077680	340x285x230	6	9	216	540
	07769	8411777077690	265x162x150	18411777077697	330x280x280	6	9	162	432
	07770	8411777077706	325x176x65	18411777077703	360x335x200	6	6	180	396
	07771	8411777077713	325x176x100	18411777077710	350x340x230	6	6	144	360
	07772	8411777077720	325x176x150	18411777077727	360x340x280	6	6	108	288
	07786	8411777077867	325x176x200	18411777077864	365x335x330	6	6	108	252
	07773	8411777077737	325x265x65	18411777077734	335x280x360	6	8	150	300
	07774	8411777077744	325x265x100	18411777077741	330x275x390	6	10	108	270
	07775	8411777077751	325x265x150	18411777077758	335x275x440	6	9	108	270
	07776	8411777077768	325x265x200	18411777077765	330x280x495	6	8	96	192
	07777	8411777077775	530x325x65	18411777077772	540x340x350	6	5	90	180
	07778	8411777077782	530x325x100	18411777077789	540x340x390	6	5	60	150
	07779	8411777077799	530x325x150	18411777077796	530x340x440	6	5	60	150
	07780	8411777077805	530x325x200	18411777077802	535x335x500	6	5	72	144
	44010	8411777440104	176x108x65	18411777440101	185x220x130	6	20	960	2040
	44011	8411777440111	176x108x100	18411777440118	220x185x175	6	20	720	1560
	47797	8411777477971	176x162x100	18411777477978	330x185x203	6	13	390	858
	47798	8411777477988	176x162x150	18411777477985	330x185x240	6	14	336	756
	47819	8411777478190	325x176x100	18411777478197	360x345x190	6	6	180	432
	47820	8411777478206	325x176x150	18411777478203	360x345x240	6	6	144	324
	47822	8411777478220	325x265x100	18411777478227	330x280x290	6	8	144	336
	47823	8411777478237	325x265x150	18411777478234	340x280x345	6	8	144	288
	47834	8411777478343	325x265x200	18411777478340	335x280x400	6	9	108	270
	47826	8411777478268	530x325x65	18411777478265	540x335x225	6	5	120	300
	47827	8411777478275	530x325x100	18411777478272	540x335x290	6	5	90	210
	47828	8411777478282	530x325x150	18411777478289	540x335x340	6	5	90	180
	47835	8411777478350	530x325x200	18411777478357	535x335x395	6	5	60	150
	02393	8411777023932	135x15	18411777023939	230x170x115	18	21	3402	7560
	02395	8411777023956	72x25x9	18411777023953	230x170x115	18	21	3402	7560
	09796	8411777097964	176x162x65	18411777097961	330x190x150	6	14	588	1260

















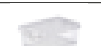

















		ITEM	EAN13 GTIN-13	Product Dimensions L x W x H (mm)	DUN 14 GTIN-14	Box Dimensions L x W x H (mm)				
	09797	8411777097971	176x162x100	18411777097978	330x185x203	6	13	390	858	
	09798	8411777097988	176x162x150	18411777097985	330x185x240	6	14	336	756	
	09816	8411777098169	265x162x65	18411777098166	340x285x150	6	8	336	720	
	09817	8411777098176	265x162x100	18411777098173	340x280x190	6	8	240	576	
	09818	8411777098183	265x162x150	18411777098180	340x280x240	6	8	192	432	
	09808	8411777098084	325x176x65	18411777098081	360x335x160	6	6	216	504	
	09819	8411777098190	325x176x100	18411777098197	360x345x190	6	6	180	432	
	09820	8411777098206	325x176x150	18411777098203	360x345x240	6	6	144	324	
	09831	8411777098312	325x176x200	18411777098319	365x335x290	6	6	108	252	
	09821	8411777098213	325x265x65	18411777098210	330x280x255	6	8	192	432	
	09822	8411777098220	325x265x100	18411777098227	330x280x290	6	8	144	336	
	09823	8411777098237	325x265x150	18411777098234	340x280x345	6	8	144	288	
	09834	8411777098343	325x265x200	18411777098340	335x280x400	6	9	108	270	
	09825	8411777098251	530x325x150	18411777098258	540x350x345	6	4	72	144	
	09826	8411777098268	530x325x65	18411777098265	540x335x225	6	4	96	240	
	09827	8411777098275	530x325x100	18411777098272	540x335x290	6	4	72	168	
	09828	8411777098282	530x325x150	18411777098289	540x335x340	6	5	90	180	
	09835	8411777098350	530x325x200	18411777098357	535x335x395	6	4	48	120	
	09824	8411777098244	325x265x20	18411777098241	330x280x90	6	8	576	1200	
	09829	8411777098299	530x325x20	18411777098296	540x335x90	6	5	360	750	
	09781	8411777097810	176x162x65	18411777097817	330x190x210	6	14	420	840	
	09782	8411777097827	176x162x100	18411777097824	330x185x225	6	14	336	840	
	09783	8411777097834	176x162x150	18411777097831	330x190x280	6	14	252	672	
	09767	8411777097674	265x162x65	18411777097671	340x280x190	6	8	240	576	
	09768	8411777097681	265x162x100	18411777097688	340x285x230	6	9	216	540	
	09769	8411777097698	265x162x150	18411777097695	330x280x280	6	9	162	432	
	09770	8411777097704	325x176x65	18411777097701	360x335x200	6	6	180	396	
	09771	8411777097711	325x176x100	18411777097718	350x340x230	6	6	144	360	
	09772	8411777097728	325x176x150	18411777097725	360x340x280	6	6	108	288	
	09786	8411777097865	325x176x200	18411777097862	365x335x330	6	6	108	216	
	09773	8411777097735	325x265x65	18411777097732	335x280x360	6	8	144	288	



































		ITEM	EAN13 GTIN-13	Product Dimensions L x W x H (mm)	DUN 14 GTIN-14	Box Dimensions L x W x H (mm)				
		09774	8411777097742	325x265x100	18411777097749	330x275x390	6	9	108	270
		09775	8411777097759	325x265x150	18411777097756	335x275x440	6	9	108	270
		09776	8411777097766	325x265x200	18411777097763	330x280x495	6	8	96	192
		09777	8411777097773	530x325x65	18411777097770	540x340x350	6	5	90	180
		09778	8411777097780	530x325x100	18411777097787	540x340x390	6	5	60	150
		09779	8411777097797	530x325x150	18411777097794	530x340x440	6	5	60	150
		09780	8411777097803	530x325x200	18411777097800	535x335x500	6	5	60	120
		04014	8411777040144	176x108x20	18411777040141	185x220x75	6	20	1680	3600
		09852	8411777098527	176x162x22	18411777098524	180x170x140	6	28	1176	2688
		09853	8411777098534	265x162x22	18411777098531	275x170x160	6	17	612	1428
		09854	8411777098541	325x176x22	18411777098548	340x185x160	6	14	504	1176
		09855	8411777098558	325x265x22	18411777098555	340x280x160	6	8	288	672
		09856	8411777098565	530x325x22	18411777098562	540x345x166	6	4	144	312
		91811	8411777918115	167x103x10	18411777918112	295x170x125	10	18	1440	3240
		91812	8411777918122	167x154x10	18411777918129	295x215x135	10	14	1120	2380
		91813	8411777918139	252x154x10	18411777918136	380x205x125	10	11	880	1980
		91814	8411777918146	309x167x10	18411777918143	445x215x130	10	7	560	1190
		91815	8411777918153	309x252x10	18411777918150	440x320x80	6	6	468	1008
		91816	8411777918160	336x309x10	18411777918167	390x315x90	6	8	576	1200
		91817	8411777918177	503x309x10	18411777918174	415x400x140	6	6	252	576
		94013	8411777940130	176x108x13	18411777940137	185x120x105	6	39	2340	4914
		94018	8411777940185	176x162x27	18411777940182	180x175x125	6	24	1152	2592
		94022	8411777940222	265x162x27	18411777940229	275x175x125	6	18	864	1944
		94029	8411777940291	325x176x27	18411777940298	330x190x130	6	14	672	1428
		94038	8411777940383	325x265x27	18411777940380	350x280x130	6	8	384	816
		94054	8411777940543	530x162x27	18411777940540	540x175x115	6	8	432	960
		94062	8411777940628	530x325x27	18411777940625	535x340x125	6	4	192	432
		84013	8411777840133	176x108x13	18411777840130	185x120x105	6	39	2340	4914
		84018	8411777840188	176x162x27	18411777840185	180x175x125	6	24	1152	2592
		84022	8411777840225	265x162x27	18411777840222	275x175x125	6	18	864	1944
		84029	8411777840294	325x176x27	18411777840291	335x190x130	6	14	672	1428



































		ITEM	EAN13 GTIN-13	Product Dimensions L x W x H (mm)	DUN 14 GTIN-14	Box Dimensions L x W x H (mm)				
		84038	8411777840386	325x265x27	18411777840383	350x280x130	6	8	384	816
		84054	8411777840546	530x162x27	18411777840543	540x175x115	6	8	432	960
		84062	8411777840621	530x325x27	18411777840628	540x340x130	6	4	192	408
		94010	8411777940109	176x108x165	18411777940106	225x190x135	6	20	960	2040
		94011	8411777940116	176x108x100	18411777940113	225x190x170	6	20	720	1560
		94012	8411777940123	176x108x150	18411777940120	225x185x210	6	20	480	1200
		94015	8411777940154	176x162x65	18411777940151	335x190x155	6	14	588	1176
		94016	8411777940161	176x162x100	18411777940168	320x185x170	6	14	504	1092
		94017	8411777940178	176x162x150	18411777940175	330x185x240	6	14	336	756
		94019	8411777940192	265x162x65	18411777940199	345x285x160	6	8	288	672
		94020	8411777940208	265x162x100	18411777940205	345x285x195	6	8	240	528
		94021	8411777940215	265x162x150	18411777940212	340x285x240	6	8	192	432
		94025	8411777940253	325x176x65	18411777940250	340x340x155	6	6	252	504
		94026	8411777940260	325x176x100	18411777940267	340x340x185	6	6	180	432
		94027	8411777940277	325x176x150	18411777940274	360x350x23	6	6	144	360
		94034	8411777940345	325x265x65	18411777940342	335x280x260	6	8	192	384
		94035	8411777940352	325x265x100	18411777940359	335x280x229	6	8	192	480
		94036	8411777940369	325x265x150	18411777940366	340x280x345	6	8	144	288
		94037	8411777940376	325x265x200	18411777940373	335x285x410	6	9	108	270
		94051	8411777940512	530x162x100	18411777940519	540x320x195	6	4	120	264
		94052	8411777940529	530x162x150	18411777940526	540x340x255	6	4	96	216
		94058	8411777940581	530x325x65	18411777940588	540x335x225	6	4	96	240
		94059	8411777940598	530x325x100	18411777940595	540x335x290	6	4	72	168
		94060	8411777940604	530x325x150	18411777940601	540x350x345	6	4	72	144
		94061	8411777940611	530x325x200	18411777940618	535x335x395	6	4	48	120
		94073	8411777940734	176x162x130	18411777940731	320x185x205	6	14	420	924
		94075	8411777940758	325x176x130	18411777940755	345x335x195	6	6	180	396
		94076	8411777940765	325x265x130	18411777940762	335x280x270	6	8	192	384
		94078	8411777940789	530x325x130	18411777940786	545x340x300	6	4	72	168
		00254	8411777002548	208x100x20	18411777002545	250x225x140	24	15	2520	5760
		00243	8411777002432	208x100x20	18411777002439	375x225x130	24	10	1920	4080



































	ITEM	EAN13 GTIN-13	Product Dimensions L x W x H (mm)	DUN 14 GTIN-14	Box Dimensions L x W x H (mm)				
	00242	8411777002425	260x115x20	18411777002422	245x240x290	24	12	864	2016
	00241	8411777002418	260x205x20	18411777002415	285x210x235	12	12	576	1296
	01923	8411777019232	312x283x20	18411777019239	320x300x270	12	8	384	768
	00256	8411777002562	470x265x20	18411777002569	480x290x250	12	6	288	648
	00393	8411777003934	138x19	18411777003931	150x110x90	48	21	12096	25200
	00394	8411777003941	210x57	18411777003948	230x170x130	36	21	6048	12852
	61390	8411777613904	176x162x150	18411777613901	485x190x310	6	9	162	378
	61392	8411777613928	265x162x150	18411777613925	475x275x310	6	6	108	252
	61393	8411777613935	325x176x150	18411777613932	530x335x320	6	5	90	210
	61391	8411777613911	325x265x150	18411777613918	530x340x350	6	5	90	180
	61397	8411777613973	530x325x150	18411777613970	540x340x545	6	4	48	96
	61376	8411777613768	60x203	18411777613765	250x250x220	16	12	960	1920
	61172	8411777611726	530x396x159	18411777611723	540x430x625	6	4	24	72
	68001	8411777680012	530x396x159	18411777680019	540x430x635	4	4	16	48
	60103	8411777601031	304x204x19	18411777601038	315x225x125	6	12	576	1296
	60102	8411777601024	404x304x24	18411777601021	410x320x150	6	6	252	540
	60101	8411777601017	504x304x34	18411777601014	510x330x145	4	5	140	300
	60858	8411777608580	604x404x24	18411777608587	610x410x110	4	3	120	240
	60859	8411777608597	604x404x34	18411777608594	610x410x110	3	4	120	240
	04069	8411777040694	650x530x300	18411777040691	660x545x405	2	2	8	20
	04070	8411777040700	650x530x380	18411777040707	660x545x480	2	2	8	16
	04079	8411777040793	650x530x300	18411777040790	660x545x405	2	2	8	20
	04080	8411777040809	650x530x380	18411777040806	660x545x480	2	2	8	16
	04071	8411777040717	650x530x20	18411777040714	640x560x55	2	2	80	164
	74069	841177740693	650x530x300	1841177740690	660x545x405	2	2	8	20
	74070	841177740709	650x530x380	1841177740706	660x545x480	2	2	8	16
	74079	841177740792	650x530x300	1841177740799	660x545x405	2	2	8	20
	74080	841177740808	650x530x380	1841177740805	660x545x480	2	2	8	16
	74071	841177740716	650x530x20	1841177740713	640x560x55	2	2	80	164
	61223	8411777612235	580x490x140	18411777612232	670x170x170	1	7	42	91
	01828	8411777018280	530x325x200	18411777018287	550x335x350	3	4	36	72



































		ITEM	EAN13 GTIN-13	Product Dimensions L x W x H (mm)	DUN 14 GTIN-14	Box Dimensions L x W x H (mm)				
		01260	8411777012608	530x396x285	18411777012605	540x430x430	2	4	16	40
		06041	8411777060418	600x400x100	18411777060415	600x400x460	5	4	40	80
		06040	8411777060401	600x400x23,5	18411777060408	610x410x80	5	4	200	400
		61226	8411777612266	620x460x1840	18411777612263	685x85x1835	1	14	14	14
		01829	8411777018297	650x530x318	18411777018294	650x535x415	1	2	4	10
		00919	8411777009196	655x435x560	18411777009193	670x430x610	2	2	4	12
		00920	8411777009202	705x465x580	18411777009209	710x480x640	2	2	4	12
		00918	8411777009189	565x340x400	18411777009186	600x360x650	4	4	16	48
		09144	8411777091443	565x340x200	18411777091440	590x345x485	6	4	48	96
		09145	8411777091450	415x340x200	18411777091457	455x350x485	6	5	60	120
		09146	8411777091467	395x200x200	18411777091464	410x215x490	6	10	120	240
		09308	8411777093089	480x230x227	18411777093086	480x240x505	6	7	84	168
		09457	8411777094574	250x80x55	18411777094571	265x220x170	12	13	936	2028
		09459	8411777094598	280x120x120	18411777094595	430x270x180	6	7	252	504
		09469	8411777094697	330x150x140	18411777094694	570x170x215	4	8	160	320
		09265	8411777092655	126x110x120	18411777092652	340x150x130	6	18	864	1836
		31851	8411777318519	195x195x100	18411777318516	390x210x235	6	11	264	594
		31852	8411777318526	195x195x190	18411777318523	390x210x350	6	11	198	396
		31853	8411777318533	235x235x190	18411777318530	480x250x375	6	7	84	252
		31854	8411777318540	235x235x230	18411777318547	480x250x415	6	7	84	210
		31855	8411777318557	290x290x210	18411777318554	580x325x415	6	5	60	150
		31856	8411777318564	290x290x320	18411777318561	580x325x535	6	5	60	120
		31857	8411777318571	290x290x400	18411777318578	580x325x615	6	5	30	90
		11851	8411777118515	195x195x100	18411777118512	390x210x235	6	11	264	594
		11852	8411777118522	195x195x190	18411777118529	390x210x350	6	11	198	396
		11853	8411777118539	235x235x190	18411777118536	480x250x375	6	7	84	252
		11854	8411777118546	235x235x230	18411777118543	480x250x415	6	7	84	210
		11855	8411777118553	290x290x210	18411777118550	580x325x415	6	5	60	150
		11856	8411777118560	290x290x320	18411777118567	580x325x535	6	5	60	120
		11857	8411777118577	290x290x400	18411777118574	580x325x615	6	5	30	90
		09292	8411777092921	530x325x65	18411777092928	535x340x390	6	5	60	150
		09293	8411777092938	530x325x100	18411777092935	535x340x390	6	5	60	150



		ITEM	EAN13 GTIN-13	Product Dimensions L x W x H (mm)	DUN 14 GTIN-14	Box Dimensions L x W x H (mm)				
		09297	8411777092976	325x265x100	18411777092973	335x285x350	6	9	162	324
		99863	8411777998636	530x325x100	18411777998633	540x355x555	7	5	35	140
		91184	8411777911840	380x265x155	18411777911847	385x275x485	6	8	96	192
		91185	8411777911857	380x265x230	18411777911854	385x275x600	6	6	36	108
		00446	8411777004467	ø 385x385	18411777004464	410x410x700	4	6	24	72
		00448	8411777004481	415x415x500	18411777004488	430x420x810	4	6	24	48
		70378	841177703780	354x325x200	1841177703787	540x425x665	6	4	24	72
		73056	841177730564	290x290x40	1841177730561	305X305X315	8	8	192	448
		31211	8411777312111	153x124x71	18411777312118	235x175x175	12	21	1512	3276
		31213	8411777312135	153x124x71	18411777312132	315x225x125	18	12	1728	3888
		61222	8411777612228	550x380x1745	18411777612225	625x95x1725	1	12	0	12
		03406	8411777034068	975x475x1.671	18411777034065	920x555x200	1	2	10	22
		00950	8411777009509	890 < 1.350x1.671	18411777009506	805x605x210	1	2	10	20
		00951	8411777009516	1.390 < 1.840 1.671	18411777009513	805x605x270	1	2	8	16
		00960	8411777039605	890 < 1.350x 480x1.671	18411777039602	805x605x210	1	2	10	20
		00961	8411777039612	1.390 < 1.840x 480xx1.671	18411777039619	805x605x270	1	2	8	16
		00952	8411777009523	460x39,5x70	18411777009520	475x95x110	1	18	180	360
		18861	8411777188617	562X372X397	18411777188614	570x390x410	1	4	8	20
		18862	8411777188624	357X321X397	18411777188621	360x340x440	1	6	12	30
		19861	'8411777198616	562X372X397	18411777198613	570x390x410	1	4	8	20
		19862	'8411777198623	357X312X397	18411777198620	360x340x440	1	6	12	30
		18227	8411777182271	562x372x397	18411777182278	570x380x415	1	4	8	20
		18237	8411777182370	357x312x397	18411777182377	360x380x415	1	6	12	30
		18240	8411777182400	H100	18411777182407	230x170x115	1	21	189	420
HANDLING										
		08101	8411777081017	504x304x34	18411777081014	510x330x145	4	5	140	300
		00101	8411777001015	504x304x34	18411777001012	510x330x145	4	5	140	300
		02101	8411777021013	504x304x34	18411777021010	510x330x145	4	5	140	300
		03101	8411777031012	504x304x34	18411777031019	510x330x145	4	5	140	300
		05101	8411777051010	504x304x34	18411777051017	510x330x145	4	5	140	300
		07101	8411777071018	504x304x34	18411777071015	510x330x145	4	5	140	300



































		ITEM	EAN13 GTIN-13	Product Dimensions L x W x H (mm)	DUN 14 GTIN-14	Box Dimensions L x W x H (mm)				
		60101	8411777601017	504x304x34	18411777601014	510x330x145	4	5	140	300
		22101	8411777221017	504x304x34	18411777221014	510x330x145	4	5	140	300
		08102	8411777081024	404x304x24	18411777081021	410x320x150	6	6	252	540
		00102	8411777001022	404x304x24	18411777001029	410x320x150	6	6	252	540
		02102	8411777021020	404x304x24	18411777021027	410x320x150	6	6	252	540
		03102	8411777031029	404x304x24	18411777031026	410x320x150	6	6	252	540
		05102	8411777051027	404x304x24	18411777051024	410x320x150	6	6	252	540
		07102	8411777071025	404x304x24	18411777071022	410x320x150	6	6	252	540
		60102	8411777601024	404x304x24	18411777601021	410x320x150	6	6	252	540
		22102	8411777221024	404x304x24	18411777221021	410x320x150	6	6	252	540
		08103	8411777081031	304x204x19	18411777081038	315x225x125	6	12	576	1296
		00103	8411777001039	304x204x19	18411777001036	315x225x125	6	12	576	1296
		02103	8411777021037	304x204x19	18411777021034	315x225x125	6	12	576	1296
		03103	8411777031036	304x204x19	18411777031033	315x225x125	6	12	576	1296
		05103	8411777051034	304x204x19	18411777051031	315x225x125	6	12	576	1296
		07103	8411777071032	304x204x19	18411777071039	315x225x125	6	12	576	1296
		60103	8411777601031	304x204x19	18411777601038	315x225x125	6	12	576	1296
		22103	8411777221031	304x204x19	18411777221038	315x225x125	6	12	576	1296
		00858	8411777008588	604x404x24	18411777008585	610x410x110	4	3	120	240
		22858	8411777228580	604x404x24	18411777228587	610x410x110	4	3	120	240
		03858	8411777038585	604x404x24	18411777038582	610x410x110	4	3	120	240
		05858	8411777058583	604x404x24	18411777058580	610x410x110	4	3	120	240
		07858	8411777078581	604x404x24	18411777078588	610x410x110	4	3	120	240
		60858	8411777608580	604x404x24	18411777608587	610x410x110	4	3	120	240
		32858	8411777328587	604x404x24	18411777328584	610x410x110	4	3	120	240
		00859	8411777008595	604x404x34	18411777008592	610x410x110	3	3	90	180
		22859	8411777228597	604x404x34	18411777228594	610x410x110	3	3	90	180
		03859	8411777038592	604x404x34	18411777038599	610x410x110	3	3	90	180
		05859	8411777058590	604x404x34	18411777058597	610x410x110	3	3	90	180
		07859	8411777078598	604x404x34	18411777078595	610x410x110	3	3	90	180
		60859	8411777608597	604x404x34	18411777608594	610x410x110	3	4	120	240



































	ITEM	EAN13 GTIN-13	Product Dimensions L x W x H (mm)	DUN 14 GTIN-14	Box Dimensions L x W x H (mm)				
	32859	8411777328594	604x404x34	18411777328591	610x410x110	3	4	120	240
	00554	8411777005549	70x193	18411777005546	250x250x225	16	12	768	1920
	02554	8411777025547	70x193	18411777025544	250x250x225	16	12	768	1920
	05554	8411777055544	70x193	18411777055541	250x250x225	16	12	768	1920
	00555	8411777005556	70x233	18411777005553	250x250x270	16	12	768	1536
	02555	8411777025554	70x233	18411777025551	250x250x270	16	12	768	1536
	05555	8411777055551	70x233	18411777055558	250x250x270	16	12	768	1536
	00556	8411777005563	75x273	18411777005560	315x315x270	16	8	512	1024
	02556	8411777025561	75x273	18411777025568	315x315x270	16	8	512	1024
	05556	8411777055568	75x273	18411777055565	315x315x270	16	8	512	1024
	00557	8411777005570	80x312	18411777005577	313x313x325	16	8	384	768
	02557	8411777025578	80x312	18411777025575	313x313x325	16	8	384	768
	05557	8411777055575	80x312	18411777055572	313x313x325	16	8	384	768
	61376	8411777613768	70x193	18411777613765	250x250x220	16	12	960	1920
	01376	8411777013766	70x193	18411777013763	250x250x220	16	12	960	1920
	01377	8411777013773	70x233	18411777013770	250x250x275	16	12	768	1536
	01378	8411777013780	75x273	18411777013787	310x310x275	16	8	512	1024
	01379	8411777013797	80x312	18411777013794	313x313x325	16	8	384	768
	71276	8411777712768	70x193	18411777712765	250x250x225	16	12	768	1920
	71277	8411777712775	70x233	18411777712772	250x250x270	16	12	768	1536
	71278	8411777712782	75x273	18411777712789	315x315x270	16	8	512	1024
	71279	8411777712799	80x312	18411777712796	313x313x325	16	8	384	768
	01380	8411777013803	60x162	18411777013800	250x250x175	16	12	1152	2496
	01381	8411777013810	60x210	18411777013817	250x250x220	16	15	1200	2400
	71280	8411777712805	60x162	18411777712802	250x250x120	16	12	1728	3648
	71281	8411777712812	60x210	18411777712819	250x250x220	16	12	960	1920
	00847	8411777008472	75x270	18411777008479	310x310x290	16	8	384	896
	21376	8411777213760	70x193	18411777213767	250x250x220	16	12	960	1920
	21377	8411777213777	70x233	18411777213774	250x250x275	16	12	768	1536
	21378	8411777213784	75x273	18411777213781	310x310x275	16	8	512	1024
	21379	8411777213791	80x312	18411777213798	313x313x325	16	8	384	768





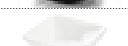





























		ITEM	EAN13 GTIN-13	Product Dimensions L x W x H (mm)	DUN 14 GTIN-14	Box Dimensions L x W x H (mm)				
		51376	8411777513761	70x193	18411777513768	250x250x220	16	12	960	1920
		51377	8411777513778	70x233	18411777513775	283x283x245	16	12	768	1536
		51378	8411777513785	75x273	18411777513782	310x310x275	16	8	512	1024
		51379	8411777513792	80x312	18411777513799	313x313x325	16	8	384	768
		03377	8411777033771	75x212	8411777033771	250x255x270	16	12	768	1536
		00954	8411777019546	70x206	18411777019543	280x285x244	16	12	768	1536
		00955	8411777019553	75x246	18411777019550	297x310x285	16	8	384	768
		00956	8411777019560	75x286	18411777019567	303x303x285	16	8	384	896
		00957	8411777009578	65x40	18411777009575	185x175x145	6	24	1008	2016
		00958	8411777009585	57x18	18411777009582	185x175x146	6	24	1008	2016
		03378	8411777033788	80x253	8411777033788	310x310x270	16	8	512	1024
		01373	8411777013735	48x110	8411777013735	360x370x150	25	6	1050	2250
		01374	18411777013749	50x138	8411777013742	360x370x150	25	6	1050	2250
		01375	18411777013756	56x167	8411777013759	385x390x185	25	6	750	1800
		01474	8411777014749	325x265x100	18411777014746	530x335x320	6	5	90	210
		01473	8411777014732	325x176x100	18411777014739	360x335x310	6	6	108	252
		01472	8411777014725	325x176x150	18411777014722	530x335x320	6	5	90	210
		03784	8411777037847	300x150x20	18411777037844	230x170x115	6	21	1134	2520
		02784	8411777027848	300x150x20	18411777027845	230x170x115	6	21	1134	2520
		03785	8411777037854	176x108x190	18411777037851	325x190x210	3	14	210	420
		03786	8411777037861	176x162x190	18411777037868	355x345x210	4	6	120	240
		03787	8411777037878	265x162x190	18411777037875	485x275x200	3	6	90	198
		01362	8411777013629	176x108x190	18411777013626	325x185x203	3	14	210	462
		01367	8411777013674	176x162x190	18411777013671	350x345x210	4	6	120	240
		01358	8411777013582	265x162x190	18411777013589	485x275x200	3	6	90	198
		01360	8411777013605	354x325x195	18411777013602	380x345x220	1	6	30	60
		01359	8411777013599	354x325x195	18411777013596	380x345x220	1	6	30	60
		01363	8411777013636	380x225x195	18411777013633	385x270x205	1	8	40	88
		01361	8411777013612	380x225x195	18411777013619	385x270x205	1	8	40	88
		01368	8411777013681	290x290x320	18411777013688	310x320x480	3	8	48	96
		02368	8411777023680	85x55x45	18411777023687	230x170x115	6	21	1134	2520



































		ITEM	EAN13 GTIN-13	Product Dimensions L x W x H (mm)	DUN 14 GTIN-14	Box Dimensions L x W x H (mm)				
		01366	8411777013667	157x243	18411777013664	530x360x275	6	5	120	240
		01365	8411777013650	147x215	18411777013657	485x310x250	6	5	120	270
		01364	8411777013643	116x164	18411777013640	385x255x190	6	7	210	504
		02366	8411777023666	157x243	18411777023663	530x355x260	6	5	120	240
		02365	8411777023659	147x215	18411777023656	485x315x245	6	5	120	270
		02364	8411777023642	116x164	18411777023649	390x250x185	6	7	210	504
		14129	8411777141292	300x205x60	18411777141299	315x225x322	24	12	864	2016
		14130	8411777141308	345x235x75	18411777141305	350x260x365	24	10	720	1440
		14131	8411777141315	435x285x80	18411777141312	435x290x230	12	6	288	720
		75132	8411777751323	485x335x80	18411777751320	485x345x255	12	5	240	540
		75133	8411777751330	540x385x80	18411777751337	535x395x263	12	4	192	384
		01129	8411777011298	300x205x60	18411777011295	315x225x322	24	12	864	2016
		01130	8411777011304	345x235x75	18411777011301	350x260x365	24	10	720	1440
		01131	8411777011311	435x285x80	18411777011318	435x290x230	12	6	288	720
		01132	8411777011328	485x335x80	18411777011325	485x345x255	12	5	240	540
		01133	8411777011335	540x385x80	18411777011332	535x395x263	12	4	192	384
		01134	8411777011342	440x350x160	18411777011349	465x385x490	12	5	120	240
		01170	8411777011700	530x396x139	18411777011707	530x410x445	6	4	48	120
		01171	8411777011717	530x396x205,5	18411777011714	530x410x520	6	4	48	96
		03171	8411777031715	530x396x205,5	18411777031712	530x410x520	6	4	48	96
		01178	8411777011786	432x332x12	18411777011783	445x335x150	12	6	504	1080
		01179	8411777011793	370x215x10	18411777011790	375x225x130	12	10	960	2040
		01180	8411777011809	416x262x10	18411777011806	420x275x130	12	7	672	1428
		01182	8411777011823	375x300x12	18411777011820	380x310x155	12	8	672	1344
		00282	8411777002821	530x325x65	18411777002828	530x335x455	12	5	120	300
		00283	8411777002838	530x325x100	18411777002835	535x335x470	12	4	96	192
		00290	8411777002906	530x325x100	18411777002903	530x335x455	4	5	40	100
		01070	8411777010703	130x60	18411777010700	275x150x180	24	20	2880	5760
		01071	8411777010710	170x80	18411777010717	360x190x190	24	12	1440	3456
		01072	8411777010727	235x110	18411777010724	250x250x265	12	15	720	1440
		01073	8411777010734	280x140	18411777010731	305x305x305	12	8	288	672



































		ITEM	EAN13 GTIN-13	Product Dimensions L x W x H (mm)	DUN 14 GTIN-14	Box Dimensions L x W x H (mm)				
		01074	8411777010741	325x160	18411777010748	345x345x260	6	6	144	288
		01075	8411777010758	380x180	18411777010755	400x400x295	6	6	108	252
		91072	8411777010727	235x110	18411777010724	250x250x265	12	15	720	1440
		91073	8411777010734	280x140	18411777010731	305x305x305	12	8	288	672
		91074	8411777010741	325x160	18411777010748	345x345x260	6	6	144	288
		91075	8411777010758	380x180	18411777010755	400x400x295	6	6	108	252
		00252	8411777002524	310x120	18411777002521	315x315x310	10	8	240	560
		00253	8411777002531	355x140	18411777002538	360x360x300	8	6	144	336
		01076	8411777010765	235x120	18411777010762	250x250x375	6	7	126	252
		01082	8411777010826	235x105	18411777010823	245x250x305	12	15	540	1260
		01083	8411777010833	280x123	18411777010830	290x300x375	12	8	192	576
		00483	8411777004832	280x172	18411777004839	400x400x295	5	6	90	210
		01121	8411777011212	294x224x112	18411777011219	305x240x250	12	12	576	1296
		01123	8411777011236	400x298x130	18411777011233	405x305x260	12	8	384	768
		00679	8411777006799	290x290	18411777006796	310x320x480	6	8	96	192
		09985	8411777099852	133x22,3	18411777099859	265x220x160	10	15	900	2100
		91003	8411777910034	239x30,4	18411777910031	380x330x135	10	6	480	1020
		91004	8411777910041	286x33	18411777910048	430x360x135	10	6	480	1020
		91005	8411777910058	332,5x35	18411777910055	470x410x120	10	4	360	760
SERVING AND DISPLAY										
		01052	8411777010529	370x334x43	18411777010526	365x345x145	12	6	504	1080
		31052	8411777310520	370x334x43	18411777310527	365x345x145	12	6	504	1080
		91052	8411777910522	370x334x43	18411777910529	365x345x145	12	6	504	1080
		81052	8411777810525	370x334x78	18411777810522	380x385x455	6	6	72	180
		41050	8411777410503	370x334x43	18411777410500	365x345x145	12	6	504	1080
		31050	8411777310506	370x334x43	18411777310503	365x345x145	12	6	504	1080
		61050	8411777610507	370x334x43	18411777610504	365x345x145	12	6	504	1080
		21050	8411777210509	370x334x43	18411777210506	365x345x145	12	6	504	1080
		91050	8411777910508	370x334x43	18411777910505	365x345x145	12	6	504	1080
		81050	8411777810501	370x334x78	18411777810508	380x385x455	6	6	72	180
		61224	8411777612242	750x430x1545	18411777612249	820x95x1480	1	10	0	10
		41046	8411777410466	350x270x20	18411777410463	360x285x95	12	8	1056	2304



































		ITEM	EAN13 GTIN-13	Product Dimensions L x W x H (mm)	DUN 14 GTIN-14	Box Dimensions L x W x H (mm)				
		61046	8411777610460	350x270x20	18411777610467	360x285x95	12	8	1056	2304
		17046	8411777170469	350x270x20	18411777170466	360x285x95	12	8	1056	2304
		18046	8411777180468	350x270x20	18411777180465	360x285x95	12	8	1056	2304
		19046	8411777190467	350x270x20	18411777190464	360x285x95	12	8	1056	2304
		22046	8411777220461	350x270x20	18411777220468	360x285x95	12	8	1056	2304
		41047	8411777410473	416x305x22	18411777410470	425x320x110	12	6	720	1440
		61047	8411777610477	416x305x22	18411777610474	425x320x110	12	6	720	1440
		17047	8411777170476	416x305x22	18411777170473	425x320x110	12	6	720	1440
		18047	8411777180475	416x305x22	18411777180472	425x320x110	12	6	720	1440
		19047	8411777190474	416x305x22	18411777190471	425x320x110	12	6	720	1440
		22047	8411777220478	416x305x22	18411777220475	425x320x110	12	6	720	1440
		41048	8411777410480	458x355x25	18411777410487	460x365x110	12	5	600	1200
		61048	8411777610484	458x355x25	18411777610481	460x365x110	12	5	600	1200
		17048	8411777170483	458x355x25	18411777170480	460x365x110	12	5	600	1200
		18048	8411777180482	458x355x25	18411777180489	460x365x110	12	5	600	1200
		19048	8411777190481	458x355x25	18411777190488	460x365x110	12	5	600	1200
		22048	8411777220485	458x355x25	18411777220482	460x365x110	12	5	600	1260
		49049	8411777490499	530x370x25	18411777490496	540x380x100	12	4	528	1104
		69049	8411777690493	530x370x25	18411777690490	540x380x100	12	4	528	1104
		39049	8411777390492	530x370x25	18411777390499	540x380x100	12	4	528	1104
		79049	8411777790490	530x370x25	18411777790497	540x380x100	12	4	528	1104
		59049	8411777590496	530x370x25	18411777590493	540x380x100	12	4	528	1104
		29049	8411777290495	530x370x25	18411777290492	540x380x100	12	4	528	1104
		19049	8411777190498	530x370x25	18411777190495	540x380x100	12	4	528	1104
		61216	8411777612167	550x430x1845	18411777612164	620x142x1670	1	8	0	8
		01021	8411777010215	200x150x12	18411777010212	230x170x115	24	21	4536	10080
		41021	8411777410213	200x150x12	18411777410210	230x170x115	24	21	4536	10080
		01022	8411777010222	280x190x12	18411777010229	300x220x120	24	13	2808	5928
		41022	8411777410220	280x190x12	18411777410227	300x220x120	24	13	2808	5928
		01023	8411777010239	350x240x12	18411777010236	390x275x130	24	9	1728	3672
		14023	8411777140233	350x240x12	18411777140230	390x275x175	24	9	1296	2808

		ITEM	EAN13 GTIN-13	Product Dimensions L x W x H (mm)	DUN 14 GTIN-14	Box Dimensions L x W x H (mm)				
		01024	8411777010246	420x300x12	18411777010243	440x335x130	24	5	960	2040
		14024	8411777140240	420x300x12	18411777140247	440x335x130	24	5	960	2040
		01225	8411777012257	500x360x12	18411777012254	540x400x85	12	4	576	1296
		41225	8411777412255	500x360x12	18411777412252	540x400x85	12	4	576	1296
		01016	8411777010161	280x200x15	18411777010168	290x230x140	12	13	1092	2496
		14016	8411777140165	280x200x15	18411777140162	290x230x140	12	13	1092	2496
		01017	8411777010178	350x250x20	18411777010175	365x265x165	12	9	648	1404
		14017	8411777140172	350x250x20	18411777140179	365x265x180	12	9	648	1296
		01018	8411777010185	420x300x25	18411777010182	430x310x200	12	6	360	792
		14018	8411777140189	420x300x25	18411777140186	430x310x200	12	6	360	792
		41040	8411777410404	200x150x40	18411777410401	225x170x170	24	20	2880	6240
		01040	8411777010406	200x150x40	18411777010403	225x170x170	24	20	2880	6240
		41041	8411777410411	280x190x40	18411777410418	295x220x170	24	13	1872	4056
		01041	8411777010413	280x190x40	18411777010410	295x220x170	24	13	1872	4056
		41042	8411777410428	350x240x40	18411777410425	385x270x200	24	8	960	2112
		01042	8411777010420	350x240x40	18411777010427	385x270x200	24	8	960	2112
		00291	8411777002913	530x325x36	18411777002910	545x350x170	6	4	144	312
		00288	8411777002883	325x265x118	18411777002880	330x280x480	4	8	64	128
		00289	8411777002890	530x325x82	18411777002897	535x340x390	4	5	40	100
		91760	8411777917606	351x51x33	18411777917603	225x125x235	16	32	2048	4608
		01761	8411777017610	51x51x55	18411777017617	220x210x240	16	15	960	2160
		91761	8411777917613	51x51x55	18411777917610	220x210x240	16	15	960	2160
		01762	8411777017627	80x80x15	18411777017624	340x100x100	8	27	2376	4968
		41762	8411777417625	80x80x15	18411777417622	340x100x100	8	27	2376	4968
		01763	8411777017634	70x70x23	18411777017631	240x160x175	8	24	1152	2496
		41763	8411777417632	70x70x23	18411777417639	240x160x175	8	24	1152	2496
		91763	8411777917637	70x70x23	18411777917634	240x160x175	8	24	1152	2496
		01764	8411777017641	127x127x15	18411777017648	270x230x150	12	14	1176	2520
		41764	8411777417649	127x127x15	18411777417646	270x230x150	12	14	1176	2520
		91764	8411777917644	127x127x15	18411777917641	270x230x150	12	14	1176	2520
		01765	8411777017658	107x107x35	18411777017655	345x235x240	12	11	528	1188

		ITEM	EAN13 GTIN-13	Product Dimensions L x W x H (mm)	DUN 14 GTIN-14	Box Dimensions L x W x H (mm)				
		41765	8411777417656	107x107x35	18411777417653	345x235x240	12	11	528	1188
		91765	8411777917651	107x107x35	18411777917658	345x235x240	12	11	528	1188
		01766	8411777017665	280x280x15	18411777017662	295x135x300	5	22	330	770
		41766	8411777417663	280x280x15	18411777417660	295x135x300	5	22	330	770
		91766	8411777917668	280x280x15	18411777917665	295x135x300	5	22	330	770
		01767	8411777017672	480x240x17	18411777017679	505x270x170	10	6	360	780
		41767	8411777417670	480x240x17	18411777417677	505x270x170	10	6	360	780
		91767	8411777917675	480x240x17	18411777917672	505x270x170	10	6	360	780
		01768	8411777017689	200x70x8	18411777017686	220x160x230	12	26	1248	3120
		41768	8411777417687	200x70x8	18411777417684	220x160x230	12	26	1248	3120
		91768	8411777917682	200x70x8	18411777917689	220x160x230	12	26	1248	3120
		01769	8411777017696	121x42x20	18411777017693	250x250x150	16	12	1344	2880
		41769	8411777417694	121x42x20	18411777417691	250x250x150	16	12	1344	2880
		91769	8411777917699	121x42x20	18411777917696	250x250x150	16	12	1344	2880
		01770	8411777017702	90x22x4	18411777017709	315x105x270	20	26	2080	4160
		41770	8411777417700	90x22x4	18411777417707	315x105x270	20	26	2080	4160
		91770	8411777917705	90x22x4	18411777917702	315x105x270	20	26	2080	4160
		01734	8411777017344	119x40x20	18411777017341	300x205x220	8	16	640	1280
		41734	8411777417342	119x40x20	18411777417349	300x205x220	8	16	640	1280
		91734	8411777917347	119x40x20	18411777917344	300x205x220	8	16	640	1280
		91735	8411777917354	56x43	18411777917351	250x205x175	4	18	432	936
		41736	8411777417366	60x64	18411777417363	255x205x270	4	18	288	576
		91736	8411777917361	60x64	18411777917368	255x205x270	4	18	288	576
		01739	8411777017399	98x20x11	18411777017396	300x205x245	8	16	512	1152
		41739	8411777417397	98x20x11	18411777417394	300x205x245	8	16	512	1152
		91739	8411777917392	98x20x11	18411777917399	300x205x245	8	16	512	1152
		91742	8411777917422	340x209x19	18411777917429	350x230x305	5	11	165	385
		01743	8411777017436	104x160x18	18411777017433	350x230x335	12	11	396	792
		41743	8411777417434	104x160x18	18411777417431	350x230x335	12	11	396	792
		91743	8411777917439	104x160x18	18411777917436	350x230x335	12	11	396	792
		01744	8411777017443	97x79x15	18411777017440	205x205x132	4	20	640	1360

































		ITEM	EAN13 GTIN-13	Product Dimensions L x W x H (mm)	DUN 14 GTIN-14	Box Dimensions L x W x H (mm)				
		41744	8411777417441	97x79x15	18411777417448	205x205x132	4	20	640	1360
		91744	8411777917446	97x79x15	18411777917443	205x205x132	4	20	640	1360
		01745	8411777017450	90x84x32	18411777017457	205x205x230	4	20	320	800
		41745	8411777417458	90x84x32	18411777417455	205x205x230	4	20	320	800
		91745	8411777917453	90x84x32	18411777917450	205x205x230	4	20	320	800
		09484	8411777094840	215x67	18411777094847	230x230x230	12	15	720	1800
		09485	8411777094857	240x67	18411777094854	255x255x260	12	12	576	1152
		09486	8411777094864	265x67	18411777094861	280x280x240	12	12	576	1296
		09891	8411777098916	290x67	18411777098913	310x310x250	12	8	384	864
		09892	8411777098923	315x67	18411777098920	335x335x255	12	6	288	648
		99484	8411777994843	215x67	18411777994840	230x230x230	12	15	720	1800
		99485	8411777994850	240x67	18411777994857	255x255x260	12	12	576	1152
		99486	8411777994867	265x67	18411777994864	280x280x240	12	12	576	1296
		99891	8411777998919	290x67	18411777998916	310x310x250	12	8	384	864
		99892	8411777998926	315x67	18411777998923	335x335x255	12	6	288	648
		09515	8411777095151	235x110	18411777095158	250x250x265	12	15	720	1440
		09510	8411777095106	280x140	18411777095103	305x305x305	12	8	288	672
		09511	8411777095113	325x160	18411777095110	345x345x260	6	6	144	288
		09512	8411777095120	380x180	18411777095127	400x400x295	6	6	108	252
		00202	8411777002029	82x62	18411777002026	250x175x235	36	18	2592	5832
		00203	8411777002036	85x90	18411777002033	250x175x275	36	18	2592	5184
		00204	8411777002043	89x119	18411777002040	260x175x320	36	18	1944	4536
		00321	8411777003217	71x98	18411777003214	275x170x140	36	18	4536	10368
		00322	8411777003224	82x114	18411777003221	290x170x180	36	18	3888	7776
		00323	8411777003231	92x127	18411777003238	340x285x185	36	14	2520	6048
		00497	8411777004979	81x142	18411777004976	305x240x250	36	12	1728	3888
		91645	8411777916456	59x51x154	18411777916453	360x245x325	48	9	1296	3024
		91646	8411777916463	79x79x188	18411777916460	520x360x410	48	4	384	960
		91647	8411777916470	84x84x212	18411777916477	550x370x450	48	4	384	960
		91648	8411777916487	67x67x222	18411777916484	450x310x485	48	6	576	1152
		91649	8411777916494	117x117x210	18411777916491	500x380x465	24	4	192	384





		ITEM	EAN13 GTIN-13	Product Dimensions L x W x H (mm)	DUN 14 GTIN-14	Box Dimensions L x W x H (mm)				
		91643	8411777916432	87x97	18411777916439	380x380x330	48	6	864	1728
		91642	8411777916425	77x157	18411777916422	510x345x350	48	5	720	1440
		91644	8411777916449	119x169	18411777916446	510x390x370	24	4	192	576
		91641	8411777916418	86x225	18411777916415	540x370x290	24	4	288	672
		91659	8411777916593	140x97x155	18411777916590	470x365x355	24	5	360	720
		91660	8411777916609	47x76	18411777916606	335x230x285	72	11	2376	6336
		91661	8411777916616	80x226	18411777916613	530x355x500	48	4	384	768
		91662	8411777916623	82x150	18411777916620	395x355x350	48	6	864	1728
		02202	8411777022027	82x62	18411777022024	250x175x235	36	18	2592	5832
		02203	8411777022034	85x90	18411777022031	250x175x275	36	18	2592	5184
		02204	8411777022041	89x119	18411777022048	260x175x320	36	18	1944	4536
		02321	8411777023215	71x98	18411777023212	275x170x140	36	20	5040	11520
		02322	8411777023222	82x114	18411777023229	290x170x180	36	18	3888	7776
		02323	8411777023239	92x127	18411777023236	340x285x185	36	14	2520	6048
		02497	8411777024977	81x142	18411777024974	305x240x250	36	12	1728	3888
		02645	8411777026452	59x51x154	18411777026459	360x245x325	48	9	1296	3024
		41646	8411777416468	79x79x188	18411777416465	520x360x410	48	4	384	960
		41647	8411777416475	84x84x212	18411777416472	550x370x450	48	4	384	960
		41648	8411777416482	67x67x222	18411777416489	450x310x485	48	6	576	1152
		41649	8411777416499	117x117x210	18411777416496	500x380x465	24	4	192	384
		41643	8411777416437	87x97	18411777416434	380x380x330	48	6	864	1728
		41642	8411777416420	77x157	18411777416427	510x345x350	48	5	720	1440
		41644	8411777416444	119x169	18411777416441	510x390x370	24	4	192	576
		41641	8411777416413	86x225	18411777416410	540x370x290	24	4	288	672
		41659	8411777416598	140x97x155	18411777416595	470x365x355	24	5	360	720
		41660	8411777416604	47x76	18411777416601	335x230x285	72	11	2376	6336
		41661	8411777416611	80x226	18411777416618	530x355x500	48	4	384	768
		41662	8411777416628	82x150	18411777416625	395x355x350	48	6	864	1728
		91700	8411777917002	216	18411777917009	270x110x100	12	28	3696	7728
		91701	8411777917019	268	18411777917016	330x115x105	12	24	2880	6048
		91702	8411777917026	330	18411777917023	390x105x105	12	22	2640	5544

		ITEM	EAN13 GTIN-13	Product Dimensions L x W x H (mm)	DUN 14 GTIN-14	Box Dimensions L x W x H (mm)				
		91703	8411777917033	333x73	18411777917030	345x145x105	12	16	1920	4032
		41703	8411777417038	333x73	18411777417035	345x145x105	12	16	1920	4032
		91704	8411777917040	333x73	18411777917047	345x145x105	12	17	2040	4284
		41704	8411777417045	333x73	18411777417042	345x145x100	12	16	2112	4416
		91705	8411777917057	230	18411777917054	260x150x170	12	21	1512	3276
		41705	8411777417052	230	18411777417059	260x150x170	12	21	1512	3276
		91706	8411777917064	230	18411777917061	265x120x170	12	27	1944	4212
		41706	8411777417069	230	18411777417066	265x120x170	12	27	1944	4212
		01706	8411777017061	230	18411777017068	345x145x105	12	16	1920	4224
		09673	8411777096738	115x200	18411777096735	420x245x215	6	8	240	480
		09674	8411777096745	130x200	18411777096742	450x265x220	6	7	210	420
		91006	8411777910065	115x200	18411777910062	420x245x215	6	8	240	480
		91007	8411777910072	130x200	18411777910079	450x265x220	6	7	210	420
		02080	8411777020801	230x110x260	18411777020808	400x300x270	6	8	192	384
		01401	8411777113978	167x119x130	18411777113975	265x160x270	6	20	480	960
		01402	8411777113985	167x119x180	18411777113982	265x160x325	6	20	360	840
		01403	8411777113992	167x119x232	18411777113999	265x160x370	6	20	240	720
		11401	8411777114012	167x119x130	18411777114019	365x340x150	6	6	252	540
		11402	8411777114029	167x119x180	18411777114026	365x340x200	6	6	180	396
		11403	8411777114036	167x119x232	18411777114033	365x340x250	6	6	144	324
		21401	8411777214019	167x119x130	18411777214016	265x160x270	6	20	480	960
		21402	8411777214026	167x119x180	18411777214023	265x160x325	6	20	360	840
		21403	8411777214033	167x119x232	18411777214030	265x160x370	6	20	240	720
		31401	8411777314016	167x119x130	18411777314013	365x340x150	6	6	252	540
		31402	8411777314023	167x119x180	18411777314020	365x340x200	6	6	180	396
		31403	8411777314030	167x119x232	18411777314037	365x340x250	6	6	144	324
		71401	8411777714014	167x119xh130	8411777714014	365x340x150	6	6	252	540
		71402	8411777714021	167x119xh180	8411777714021	365x340x200	6	6	180	396
		71403	8411777714038	167x119xh232	8411777714038	365x340x250	6	6	144	324
		01400	8411777113961	119x119x41	18411777113968	135x125x155	6	48	2016	4032
		21400	8411777214002	119x119x41	18411777214009	135x125x155	6	48	2016	4032

		ITEM	EAN13 GTIN-13	Product Dimensions L x W x H (mm)	DUN 14 GTIN-14	Box Dimensions L x W x H (mm)				
		41128	8411777411289	530x325x100	18411777411286	540x355x555	10	5	50	200
		09863	8411777098633	530x325x100	18411777098630	540x355x555	7	5	35	140
		02037	8411777020375	112x25	18411777020372	235x235x380	24 (set4)	15	720	2160
		02077	8411777020771	160x130x105	18411777020778	450x270x125	6	7	336	756
		01010	8411777010109	280x110x48	18411777010106	286x240x256	12	12	576	1152
		02038	8411777020382	115x140	18411777020389	340x240x440	48	11	1056	2640
		01049	8411777010499	212x138x21	18411777010496	285x220x155	24	14	2352	4704
		01068	8411777010680	97x137	18411777010687	335x235x270	24	10	960	1920
		01475	8411777014756	325x265x150	18411777014753	535x345x355	4	4	48	96
		01064	8411777010642	156x81x131	18411777010649	245x162x281	6	21	378	1008
		01037	8411777010376	366x297x60	18411777010373	370x305x230	6	8	192	480
		61217	8411777612174	1030x500x980	18411777612171	240x545x915	1	6	6	12
		61221	8411777612211	950x500x945	18411777612218	515x250x870	1	6	6	12
		61218	8411777612181	330x230x175	18411777612188	330x248x195	1	10	50	110
		61219	8411777612198	330x230x560	18411777612195	385x275x600	1	8	8	24
		71134	8411777711341	440x350x160	18411777711348	465x385x490	12	5	120	240
		71170	8411777711709	530x396x139	18411777711706	530x410x445	6	4	48	120
		71171	8411777711716	530x396x205,5	18411777711713	530x410x520	6	4	48	96
		07498	8411777074989	350x260x145	18411777074986	440x270x370	3	7	63	126
		07499	8411777074996	350x260x145	18411777074993	440x270x370	3	7	63	126
		07500	8411777075009	350x260x145	18411777075006	440x270x370	3	7	63	126
		07501	8411777075016	450x349x195	18411777075013	395x360x460	2	6	24	60
		07502	8411777075023	450x349x195	18411777075020	395x360x460	2	6	24	60
		07503	8411777075030	450x349x195	18411777075037	395x360x460	2	6	24	60
TRANSPORT										
		41500	8411777415003	420x657x379	18411777415000	660x400x435	1	3	6	15
		41819	8411777418196	680x477x620	18411777418193	690x500x650	1	2	2	6
		41818	8411777418189	710x530x230	18411777418186	735x550x270	1	2	8	16
		01810	8411777018105	420x230x470	18411777018102	430x250x485	1	7	14	28
		01172	8411777011724	530x396x159	18411777011721	540x430x625	6	4	24	72
		91172	8411777911727	530x396x159	18411777911724	540x430x625	6	4	24	72

		ITEM	EAN13 GTIN-13	Product Dimensions L x W x H (mm)	DUN 14 GTIN-14	Box Dimensions L x W x H (mm)				
		01173	8411777011731	530x396x225,5	18411777011738	540x425x665	6	4	24	72
		91173	8411777911734	530x396x225,5	18411777911731	540x425x665	6	4	24	72
		01183	8411777011830	530x396x378,5	18411777011837	540x425x625	4	4	16	48
		91183	8411777911833	530x396x378,5	18411777911830	540x425x625	4	4	16	48
		00545	8411777005457	830x460x180	18411777005454	845x473x555	6	2	24	48
		01850	8411777018501	600x395x410	18411777018508	610x400x745	6	4	24	72
		01870	8411777018709	655x435x455	18411777018706	660x450x735	4	2	8	24
		01890	8411777018907	705x465x480	18411777018904	720x480x780	4	2	8	16
CLEANING										
		31215	8411777312159	467x435x620	18411777312156	820x450x435	3	2	12	30
		51215	8411777512153	467x435x620	18411777512150	820x450x435	3	2	12	30
		71215	8411777712157	467x435x620	18411777712154	820x450x435	3	2	12	30
		03403	8411777034037	490x520x655	18411777034034	540x480x1020	3	2	6	12
		05403	8411777054035	490x520x655	18411777054032	540x480x1020	3	2	6	12
		07403	8411777074033	490x520x655	18411777074030	540x480x1020	3	2	6	12
		06403	8411777064034	490x520x655	18411777064031	540x480x1020	3	2	6	12
		03404	8411777034044	490x530x800	18411777034041	550x500x1090	3	2	6	12
		05404	8411777054042	490x530x800	18411777054049	550x500x1090	3	2	6	12
		07404	8411777074040	490x530x800	18411777074047	550x500x1090	3	2	6	12
		06404	8411777064041	490x530x800	18411777064048	550x500x1090	3	2	6	12
		03405	8411777034051	460x560x940	18411777034058	550x500x1210	3	2	6	6
		05405	8411777054059	460x560x940	18411777054056	550x500x1210	3	2	6	6
		07405	8411777074057	460x560x940	18411777074054	550x500x1210	3	2	6	6
		06405	8411777064058	460x560x940	18411777064055	550x500x1210	3	2	0	6
		40400	8411777404007	424x262x420	8411777404007	425x275x855	4	8	32	64
		43400	8411777434004	424x262x420	8411777434004	425x275x855	4	8	32	64
		45400	8411777454002	424x262x420	8411777454002	425x275x855	4	8	32	64
		47400	8411777474000	424x262x420	8411777464001	425x275x855	4	8	32	64
		46400	8411777464001	424x262x420	8411777444003	425x275x855	4	8	32	64
		44400	8411777444003	424x262x420	8411777444003	425x275x855	4	8	32	64
		40271	8411777402713	310x335x420	8411777402713	670x315x845	4	4	16	32

		ITEM	EAN13 GTIN-13	Product Dimensions L x W x H (mm)	DUN 14 GTIN-14	Box Dimensions L x W x H (mm)				
		43271	8411777432710	310x335x420	8411777432710	670x315x845	4	4	16	32
		45271	8411777452718	310x335x420	8411777452718	670x315x845	4	4	16	32
		47271	8411777472716	310x335x420	8411777472716	670x315x845	4	4	16	32
		46271	8411777462717	310x335x420	8411777462717	670x315x845	4	4	16	32
		44271	8411777442719	310x335x420	8411777442719	670x315x845	4	4	16	32
		40275	8411777402751	435x300x635	8411777402751	430x300x810	4	6	24	48
		43275	8411777432758	435x300x635	8411777432758	430x300x810	4	6	24	48
		45275	8411777452756	435x300x635	8411777452756	430x300x810	4	6	24	48
		47275	8411777472754	435x300x635	8411777472754	430x300x810	4	6	24	48
		46275	8411777462755	435x300x635	8411777462755	430x300x810	4	6	24	48
		44275	8411777442757	435x300x635	8411777442757	430x300x810	4	6	24	48
		08271	8411777082717	310x335x420	18411777082714	670x315x845	4	4	16	32
		40249	8411777146600	370x265x265	18411777146607	400x290x545	6	8	96	192
		40250	8411777146617	Ø 290x290	18411777146614	315x320x555	6	8	48	192
		14660	8411777146600	370x265x265	18411777146607	400x290x545	6	8	96	192
		14661	8411777146617	Ø 290x290	18411777146614	315x320x555	6	8	48	192
		42865	8411777428652	370x383x370	18411777428659	400x290x545	6	8	96	192
		42866	8411777428669	Ø 290x290	8411777428669	315x320x555	6	8	48	192
		61220	8411777612204	210x300x630	18411777612201	650x375x320	10	3	90	210
		88249	8411777882492	370x265x265	18411777882499	400x290x545	6	8	96	192
		88250	8411777882508	290x290	18411777882505	315x320x555	6	8	48	192
		81090	8411777810907	162x119x58	18411777810904	240x170x124	12	20	1920	4320
		81091	8411777810914	238x160x58	18411777810911	240x170x190	12	20	1200	2880
		81092	8411777810921	326x240x58	18411777810928	330x248x195	12	10	600	1320
		81093	8411777810938	380x265x155	18411777810935	385x275x485	6	8	96	192
		00300	8411777003002	350x250x280	18411777003009	762x285x360	3	4	36	72
		00301	8411777003019	350x250x190	18411777003016	771x265x360	4	4	48	96
		00302	8411777003026	265x180x185	18411777003023	745x190x275	4	6	96	192
		00303	8411777003033	265x180x185	18411777003030	745x190x275	4	6	96	192
		81094	8411777810945	380x265x230	18411777810942	385x275x600	6	8	48	144
		08317	8411777083172	530x396x242	18411777083179	540x425x665	6	4	24	72

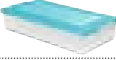
		ITEM	EAN13 GTIN-13	Product Dimensions L x W x H (mm)	DUN 14 GTIN-14	Box Dimensions L x W x H (mm)				
		91177	8411777911772	530x396x378	18411777911779	540x425x665	4	4	16	48
		03315	8411777033153	830x460x180	18411777033150	845x473x555	6	2	24	48

araven

[CFS BRANDS]

Official Sponsor

INSTITUT
Lyfe

Fundación
Cruzcampo



basque
culinary
center

wk[©]
Westminster Kingsway
central London's College

gasma
GASTRONOMY & MANAGEMENT
UNIVERSITY CAMPUS

Collaborating chefs

AKELARE
PEDRO SUBIJANA

Martin Berasategui

ENRIQUE OLVERA

**JESÚS
ALMAGRO**
COCINA & PASIÓN

Astrance
PARIS

UEMURA

**LAJA
MADA**

OUR BRANDS AT [CFS BRANDS] IN EMEA



ARAVEN S.L.U.
CFS Brands
- EMEA Offices -

Polígono Industrial San Miguel · Río Martín nº 6 · Villanueva de Gállego, Zaragoza (Spain) · T. (+34) 976 46 52 00 · www.araven.com